

Beds & Night Accessories

ADÖK

Beds & Night Accessories

I letti Adok

Adok presenta la Collezione Letti, una grande varietà di modelli e soluzioni dedicati all'oggetto d'arredo della casa più ricco di fascino e intensità emozionale. Una ricca gamma improntata alla massima versatilità stilistica e all'utilizzo di materiali differenti attentamente selezionati, capaci di coniugare eleganza formale e comfort, per rendere la nostra vita più agevole e piacevole. Con l'obiettivo di offrire ad ognuno la più grande possibilità di scelta e la garanzia, in ogni caso, di un'altissima qualità del riposo e di una soluzione personale.

The Adok beds

Adok presents the Beds Collection, a wide variety of models and solutions dedicated to the object of home furniture richer in charm and emotional intensity. A rich range of products marked by maximum stylistic versatility and the use of carefully selected different materials, capable to combine formal elegance and comfort, to make our life easier and more pleasant. With the goal of offering everyone the greater possibility of choice and the guarantee, in any case, of a very high quality of rest and a personal solution.

Accessori notte

L'ambiente notte è la zona della casa che viviamo con maggior intensità ed è per questa ragione che cerchiamo di realizzarla nel pieno rispetto delle nostre preferenze estetiche. La Collezione degli Accessori Notte Adok, progettati per essere affiancati ai pezzi della Collezione Letti e della Collezione Armadi, offre una totale libertà nella scelta dei modelli e delle forme, dei colori, delle finiture e dei materiali. Una varietà estetica improntata alla creatività e alla funzionalità: per realizzare la camera da letto dei vostri sogni.

Night accessories

The night environment is the home area we live with more intensity and it is for this reason that we try to realize it in full respect of our aesthetic preferences. The Adok Night Accessories Collection, designed to be placed side by side with pieces of the Beds Collection and Wardrobes Collection, offers a total freedom in the choice of models and shapes, colors, finishes and materials. A aesthetics variety based on creativity and functionality: to realize the bedroom of your dreams.

SISTEMA MODULA COMODINO FLY

Una composizione che attribuisce alla testiera una funzione centrale sul piano visivo, con la grande rilevanza estetica dei pannelli rivestiti in tessuto e con retroilluminazione a LED. Uno spazio notte personalizzato, caratterizzato dalle linee geometriche dei moduli utilizzati e dalla leggerezza dei comodini sospesi Fly.

A composition that attributes a central function to the headboard on the visual plane, with the aesthetic relevance of fabric coated panels and with LED backlight. A sleeping personalized space, characterized by geometric lines of the modules used and the lightness of the Fly suspended bedside tables.







Il sistema componibile Modula è composto da pannelli centrali imbottiti e rivestiti in tessuto Ada AA04 e da pannelli laterali in finitura Calce, ai quali sono applicati comodini sospesi Fly in finitura a contrasto Titanio. Il giroletto h. 14 cm, rivestito nello stesso tessuto della testiera, è completato da piedini in finitura Ghisa. La testiera è dotata di retroilluminazione a LED.

Modula modular system is composed of covered and upholstered central panels in Ada AA04 fabric and from side panels in Calce finish, to which are applied Fly suspended bedside tables in a Titanio contrasting finish. The h. 14 cm bed frame, covered in the same headboard fabric, is completed by feet in Ghisa finish. The headboard is equipped with LED backlight.







Completa l'ambiente un
armadio in nicchia con ante
Row in vetro cannettato
laccato Titanio.

The environment is
completed by a niche
wardrobe with Row doors
in lacquered Titanio
ribbed glass.



SISTEMA MODULA
COMODINO FLY
COMÒ STREAM

Un ambiente di rigorosa concezione contemporanea, caratterizzato da forme geometriche e linee ortogonali. La scelta dell'illuminazione a LED contribuisce ad accrescere la valenza emozionale della zona notte e a creare un'atmosfera magica, ma intensa e suggestiva.

An environment of rigorous contemporary design, characterized by geometric shapes and orthogonal lines. The choice of LED lighting contributes to increasing the emotional value of the night zone and to create a magical atmosphere, but intense and suggestive.





Testiera Modula composta da pannelli imbottiti e rivestiti in tessuto Ada AA01 e pannelli in finitura Rovere Caramel, abbinata al giroletto h. 28,4 cm rivestito in tessuto Ada AA01. Completano il letto due comodini sospesi Fly in finitura Canapa e una mensola sospesa in finitura Platino.

Modula Headboard is composed of covered and upholstered panels in Ada AA01 fabric and panels in Rovere Caramel finish, matched to the h. 28,4 cm upholstered bedframe in Ada AA01 fabric. Complete the bed two Fly suspended bedside tables in Canapa finish and a suspended shelf in Platino finish.



Comò Stream con fianchi, frontali e maniglie in finitura Canapa e vano a giorno in finitura Rovere Caramel. Il servetto integrato è dotato di pratico ripiano a terra porta scarpe in finitura Canapa, mentre la barra porta indumenti è in finitura Ghisa.

Stream dresser with sides, fronts and handles in Canapa finish and open compartment in Rovere Caramel finish. The integrated servetto is equipped with a practical floor standing shoes shelf in Canapa finish, while the garment holder bar is in Ghisa finish.





Variante composizione testiera
La testiera Modula è composta da due pannelli centrali imbottiti e rivestiti in tessuto Ada AA01 e due pannelli laterali in finitura Rovere Caramel.

Headboard composition variant
The Modula headboard is composed by two covered and upholstered central panels in Ada AA01 fabric and two side panels in Rovere Caramel finish.

SISTEMA MODULA COMODINO FLY

I pannelli del sistema Modula si compongono come tessere di un mosaico e personalizzare la zona letto diventa un gioco grazie alla grande varietà di materiali e giroletti disponibili.

The panels of the Modula system are composed as tiles of a mosaic and to customize the bed area becomes a game thanks to the great variety of materials and bedframes available.









Il sistema Modula con pannelli rivestiti in tessuto Ada AA06 è abbinato al giroletto h. 14 cm con piedino Plexi in plexiglass. Completano la testiera la retroilluminazione a LED e due comodini Fly a sbalzo in finitura Testa di Moro.

The Modula system with panels covered in Ada AA06 fabric is matched to the h. 14 cm beframe with Plexi foot in plexiglass. Complete the headboard the LED backlight and two cantilever Fly bedside tables in Testa di Moro finish.

SISTEMA MODULA
COMODINO FLY
VANITY SQUARE

Un'interpretazione originale dello spazio notte, connotato da una componibilità modulare della testiera attrezzata. La morbidezza dei pannelli rivestiti in tessuto con retroilluminazione a LED conferisce all'ambiente una valenza emozionale e suggestiva.

An original interpretation of the night space, characterized by a modularity of the equipped headboard. The softness of the panels covered in fabric with LED backlight gives out to the environment an emotional and suggestive value.







Il sistema Modula in questa composizione a 12 moduli è rivestito in tessuto Beatrice BB02 e abbinato a giroletto h. 28,4 cm. I comodini Fly sospesi sono in finitura Tortora. La testiera è dotata di retroilluminazione a LED.

The Modula system in this composition with 12 modules is covered in Beatrice BB02 fabric and combined with h. 28,4 cm bedframe. Fly suspended bedside tables are in Tortora finish. The headboard is equipped with LED backlight.



Il vanity Square è composto da un elemento con quattro cassetti in finitura Tortora e piano in finitura Rovere Caramel, il tutto completato da specchiera sospesa con retroilluminazione a LED e pouf in tessuto Beatrice BB02.

The Square vanity is composed of an element with four drawers in Tortora finish and top in Rovere Caramel finish, all completed with suspended mirror with LED backlight and a pouf in Beatrice BB02 fabric.



SISTEMA CARRÈ
COMODINO FLY
COMODINO POLAR

Una composizione di grande raffinatezza formale: i pannelli componibili e modulari creano una testiera di forte impatto scenografico, una boiserie caratterizzata dalla texture delle cannetture orizzontali e verticali, una modalità originale e moderna di interpretare un materiale tradizionale come il legno.

A composition of great formal refinement: the modular panels create a headboard of strong scenographic impact. A boiserie characterized by the texture of horizontal and vertical washboard effect, an original and modern mode to interpret a material as traditional as wood.









Il sistema Carré è proposto nella combinazione con un pannello centrale, con cannettatura orizzontale e illuminazione integrata a LED verticale, e due pannelli laterali con cannettatura verticale. Il giroletto imbottito h. 14 cm in tessuto Bianca BA07 è corredato da piedini trasparenti Plexi. Completano la composizione il comodino sospeso Fly in finitura laccato Brandy e il comodino Polar con struttura in finitura Platino e vassoi in finitura Brandy.

The Carré system is proposed in combination with a central panel, with horizontal and integrated vertical LED lighting, and two side panels with vertical washboard effect. The h. 14 cm upholstered bedframe in Bianca BA07 fabric is accompanied by Plexi transparent feet. Complete the composition the Fly suspended bedside table in Brandy lacquered finish and the Polar bedside table with Platino finish structure and trays in Brandy finish.





Variante A composizione testiera
Option A - Headboard composition



Variante B composizione testiera
Option B - Headboard composition

A sinistra: la variante A è composta da un pannello centrale e due pannelli laterali con cannettatura verticale.

On the left: the A option consists of a central panel and two side panels with vertical washboard effect.

A destra: la variante B è composta da un pannello centrale con cannettature alternate verticali e orizzontali e da due pannelli laterali con cannettatura orizzontale.

On the right: the B option consists of a central panel with alternate vertical and horizontal washboard effect and two side panels with horizontal washboard effect.



Tavolino Polar con tre pratici ripiani portaoggetti in finitura Brandy e struttura Platino.

Polar bedside table with three practical storage shelves in Brandy finish and Platino structure.

SISTEMA SIDE
COMODINO FLY
COMÒ CUBE

La testiera che arreda: linee dal design minimale che si uniscono alla praticità dei dettagli, per una zona notte contemporanea.
Il sistema Side è composto da un sommier tre lati, rivestito in tessuto in versione bassa o alta, oppure in legno con piedini in due versioni, e una testiera realizzata con pannelli sospesi retroilluminati.

The headboard that furnishes: minimal design lines that combine with the practicality of details, for a contemporary sleeping area.
The Side system is made up of a three-sided sommier, covered in fabric in the low or high version, or in wood with feet in two versions, and a headboard made with suspended backlit panels.





La testiera Side, in doppia finitura Calce e Cenere e retroilluminazione a LED, è accessoriata con il comodino sospeso Fly in finitura Calce e due mensole in metallo rivestite da pannelli in finitura. La mensola a sinistra è in finitura Calce e la mensola a destra è in finitura Cenere.

The Side headboard, in Calce and Cenere double finish and LED backlighting, is equipped with the Fly suspended bedside table in Calce finish and two metal shelves covered with finishing panels. The shelf on the left is in Calce finish and the shelf on the right is in Cenere finish.





Il comò Cube, qui in finitura Cenere, è caratterizzato da un elemento geometrico frontale che funge da maniglia.

The Cube dresser, here in the Cenere finish, is characterized by a front geometrical element that acts as a handle.

SISTEMA SIDE
COMODINO FLY
COMODINO E CASSETTIERA CODE

La grande testiera retroilluminata diventa protagonista della stanza e incornicia il letto. Gli spessori ridotti si adattano a spazi contemporanei, senza rinunciare a un design di grande effetto.

The large backlit headboard becomes the star of the room and frames the bed. The reduced thicknesses adapt to contemporary spaces, without giving up a design of great effect.







Nelle pagine precedenti: testiera a muro Side in finitura Rovere Caramel, abbinata a giroletto imbottito h. 28,4 cm.

In questa pagina: la testiera Side può essere accessoriata con testiera imbottita applicata al pannello.

In the previous pages: Side wall headboard in Rovere Caramel finish, combined with h. 28.4 cm upholstered bedframe.

On this page: the Side headboard can be accessorized with an upholstered headboard applied to the panel.



Alla testiera sono abbinati da un lato il comodino sospeso Fly con un cassetto e una mensola portaoggetti metallica impreziosita da pannelli in finitura, entrambi in finitura Fango, mentre dall'altro il comodino Code in finitura Fango con base Ghisa, abbinato alle cassettiere con vano a giorno.

The headboard is combined on one side with the Fly suspended bedside table with a drawer and a metal shelf embellished with finish panels, both in the Fango finish, while on the other side the Code bedside table in the Fango finish with Ghisa base, combined with the chests of drawers with open compartments.

LETTO SIRIO
COMODINO E SETTIMINO LOOP
COMODINO POLAR

Un raffinato equilibrio tra morbidezza e razionalità, tra geometria ed emozione, con la preziosità degli inserti in metallo tra un modulo e l'altro della testiera ad evidenziare la ricercatezza delle soluzioni tecniche e delle lavorazioni.

A refined balance between softness and rationality, between geometry and emotionality, with the preciousness of the inserts in metal between one module and another of the headboard to highlight the refinement of the techniques solutions and manufacturing.









La testiera Sirio in finitura Testa di Moro, con inserti in metallo Platino, è abbinata a giroletto Step nella stessa finitura con piedini Cilindro in finitura Ghisa.

The Sirio headboard in Testa di Moro finish, with Platino metal inserts. It is combined with Step bedframe into the same finish with Cilindro feet in Ghisa finish.



Settimino e comodino Loop in finitura laccato Edera, con le loro forme razionali, creano un contrasto con le linee arrotondate del comodino Polar, anch'esso in finitura laccato Edera con struttura metallica in finitura Platino.

Loop septet and bedside table in lacquered Edera finish, with their rational forms, create a contrast with the rounded lines of Polar bedside table, also in lacquered Edera finish with metal structure in Platino finish.





Variante giroletto Stilo

La testiera Sirio a quattro settori con venatura alternata in finitura Testa di Moro e inserti metallici Platino è presentata in queste pagine con giroletto Stilo, sempre in finitura Testa di Moro, e piedini in finitura Platino.

Stilo bedframe variant

The Sirio headboard with four sectors with alternating grain in Testa di Moro finish and metal Platino inserts is presented on these pages with Stilo bedframe, always in Testa di Moro, and feet in Platino finish.



LETTO SIRIO
COMÒ E COMODINI GROOVE

Una leggerezza formale derivante dall'effetto "magico" che viene creato grazie al letto "sospeso" con contenitore nascosto e all'illuminazione integrata nel bordo inferiore. Una creazione originale e suggestiva, ma di grande funzionalità.

A formal lightness resulting from the "magic" effect that comes created thanks to the "suspended" bed with hidden container and the integrated lighting in the bottom edge. An original and suggestive creation, but with great functionality.







Il letto Sirio in finitura laccata Argilla è dotato di contenitore nascosto Beauty con illuminazione a LED integrata. Il contenitore, occupando solo la parte centrale, genera un effetto di illusione ottica grazie alla quale il letto sembra essere sospeso.

The Sirio bed in lacquered Argilla finish is equipped with Beauty hidden container with integrated LED lighting. The container, occupying only the central part, generates an optical illusion effect thanks to which the bed looks to be suspended.



La cassettera e i comodini Groove sono nella finitura Natura. I frontali dei cassetti recedono su un lato per lasciare uno spazio che funge da maniglia, la cui gola è in finitura laccata Argilla.

The Groove chest of drawers and bedside tables are in Natura finish. The fronts of the drawers recede on one side to leave a space which acts as a handle, whose grip is in lacquered Argilla finish.

LETTO BLADE
COMÒ E COMODINO FLAT

Una composizione che enfatizza il carattere intimo dell'ambiente notte grazie alle piacevoli sensazioni evocate dall'utilizzo del legno, qui interpretato mediante i giochi delle geometrie e i contrasti delle finiture, la personalizzazione delle forme e l'eleganza degli abbinamenti.

A composition that emphasizes the intimate character of the night environment thanks to the pleasant sensations evoked by the use of wood, here interpreted through the games of geometries and contrasting finishes, the customization of the shapes and the elegance of the combinations.







La testiera Blade in doppia finitura con fasce verticali alternate Rovere Caramel e Argilla è abbinata al giroletto Step in Rovere Caramel e piedino Cilindro in finitura Ghisa.

The Blade headboard in double finishing with Rovere Caramel and Argilla alternate vertical bands is matched to the Step bedframe in Rovere Caramel and Cilindro foot in Ghisa finish.

Completano la zona notte il comò e il comodino Flat in finitura Argilla e presa maniglia in finitura Platino.

Complete the sleeping area the Flat dresser and the bedside table in Argilla finish and the grip handle in Platino finish.





Variante gruppo notte Aria

Nelle pagine precedenti: il letto Blade con testiera in doppia finitura Cannettè e laccato Argilla è abbinato a giroletto Step in finitura laccato Argilla con piedino Plexi. I comodini asimmetrici Aria sono in finitura Cannettè e laccato Argilla.

Nella pagina accanto: comò Aria in doppia finitura Canvas e laccato Argilla con maniglia laccata Argilla.

Aria night group variant

Previous pages: The Blade Bed with headboard in Cannettè and lacquered Argilla double finish is combined with Step bedframe in lacquered Argilla finish with Plexi foot. The Aria asymmetric bedside tables are in Cannettè and lacquered Argilla finish.

On the next page: Aria dresser in Canvas and laquered Argilla double finish with lacquered Argilla handle.



LETTO WAVE
GRUPPO NOTTE ARIA

Una testiera del letto morbida e avvolgente come un caldo abbraccio. Una composizione che valorizza l'asimmetria razionale del gruppo notte, disponibile in combinazioni diverse di finiture e colori, e la "leggerezza sospesa" dei comodini.

A soft and enveloping bed headboard like a warm embrace. A composition that enhances the rational asymmetry of the night group, available in different combinations of finishes and colors, and the "suspended lightness" of the bedside tables.







Il letto Wave con giroletto h. 28,4 cm è rivestito in tessuto Ada AA04.

The h. 28,4 cm Wave bed with bedframe is covered in Ada AA04 fabric.





Il gruppo notte Aria è caratterizzato da moduli contenitori componibili. In questa composizione sono presenti due comodini sospesi e asimmetrici, una composizione vanity sospesa e specchiera con retroilluminazione a LED.

The Aria night group is characterized of modular storage units. In this composition there are two suspended and asymmetric bedside tables, a suspended vanity composition and a mirror with LED backlight.

**Variante di composizione**

In questa variante è presentata una composizione sospesa con moduli contenitori del gruppo notte Aria. Gli elementi sono in finitura Testa di Moro e Granata, con maniglie in finitura Platino.

Composition variant

In this variant there is a suspended composition with containers modules of Aria night group. The elements are in Testa di Moro and Granata finish, with handles in Platino finish.





LETTO WAVE
COMODINO E CASSETTIERA STREAM

L'eleganza del letto in contrasto con la leggerezza visiva degli inserti in vetro del gruppo notte. Un ambiente caratterizzato dall'utilizzo di forme e materiali in modo da creare una soluzione d'arredo che consenta ad ognuno di realizzare al meglio i suoi sogni.

The elegance of the bed in contrast with the visual lightness of the glass inserts of the night group. An environment characterized from the use of shapes and materials in order to create a solution furniture that allows everyone to make his dreams come true.







La testiera imbottita Wave con giroletto h. 28,4 cm sono rivestiti in tessuto Asia AB05.

Il comodino Stream con piano in vetro Fumé Bronzo presenta un pratico vano a giorno rivestito in finitura Rovere Caramel. Frontali, fianchi e maniglia sono invece in finitura laccata Selva.

The Wave upholstered headboard with h. 28,4 cm bedframe is covered in Asia AB05 fabric.

Stream bedside table with top in Fumé Bronzo glass presents a practical open compartment covered in Rovere Caramel finish. Fronts, sides and handle are instead in lacquered Selva finish.





La cassettera Stream è caratterizzata da un piano superiore in vetro Fumé Bronzo che sormonta tre vani a giorno rivestiti in finitura Rovere Caramel. Frontali, fianchi e maniglia sono invece in finitura laccato Selva.

The Stream chest of drawers is characterized by a upper plan in Fumé Bronzo glass that surmounts three open compartments covered in Rovere Caramel finish. Fronts, sides and handle are instead in lacquered Selva finish.

LETTO WAVE
COMODINO E CASSETTIERA STREAM

L'elemento distintivo del letto Wave è l'ampia testiera dal disegno avvolgente che, abbinata al giroletto imbottito, crea un'isola di comfort all'interno della zona notte, che contrasta piacevolmente con le linee razionali dei comodini e delle cassettiere Stream.

The distinctive element of the Wave bed is the large headboard with an enveloping design which, combined with the upholstered bed frame, creates an island of comfort within the sleeping area, which contrasts pleasantly with the rational lines of the Stream bedside tables and chests of drawers.





Il letto Wave imbottito con giroletto h. 28,4 cm è rivestito nel tessuto Bianca BA06.

The Wave upholstered bed with h. 28,4 cm bedframe is covered in Bianca BA06 fabric.





Il comodino e le cassettiere Stream sono realizzati in queste pagine nella finitura laccato Argilla. Il top con bordi leggermente rialzati crea un pratico effetto vassoio.

The Stream bedside table and chest of drawers are created, in these pages, in the Argilla finish. The top with slightly raised edges creates a practical tray effect.

LETTO RUBIK
COMODINO E CASSETTIERA CODE

La lavorazione trapuntata del letto Rubik aiuta a creare un'atmosfera confortevole nella camera da letto, la zona per eccellenza del riposo.

The quilted workmanship of the Rubik bed helps to create a comfortable atmosphere in the bedroom, the relax area par excellence.





In queste pagine la testiera Rubik è abbinata al giroletto h. 28,4 cm. Testiera e giroletto sono rivestiti in tessuto Ada AA03 con bordi in tessuto Asia AB04.

On these pages the Rubik headboard is combined with the h. 28,4 cm. bed frame. Headboard and bed frame are covered in Ada AA03 fabric with Asia AB04 fabric edges.



**Variante giroletto Stilo**

In questa variante la testiera imbottita Rubik è abbinata al giroletto Stilo in finitura Rovere Caramel con piedino in finitura Ghisa.

Stilo bedframe variant

In this version Rubik upholstered headboard is combined with Stilo bedframe in Rovere Caramel finish with foot in Ghisa finish.



Il gruppo notte Code, qui nelle finiture abbinata Ghiaccio e Rovere Caramel, con base Platino, alterna vani a giorno e cassetti.

The Code night group, here in the matching Ghiaccio and Rovere Caramel finishes, with Platino base, alternates open compartments and drawers.



LETTO RUBIK
COMODINO E CASSETTIERA UNIQUE

Un letto con la testiera trapuntata in pelle che garantisce una significativa intensità espressiva ed interpreta l'ambiente notte sulla base di una cultura contemporanea dell'arredo, caratterizzata da funzionalità e originalità formale.

A bed with a quilted leather headboard that guarantees a significant expressive intensity and interprets the night environment on the basis of a contemporary culture of furniture, characterized by functionality and formal originality.







Testiera Rubik rivestita in ecopelle Barbara BC08 con giroletto imbottito h. 14 cm nella stessa finitura e piedino Forma in finitura Ghisa.

Rubik coated headboard in Barbara BC08 eco-leather with h.14 cm upholstered bedframe in the same finish and Forma foot in Ghisa finish.

Il comodino Unique con due cassetti e maniglia a gola è in finitura Cenere.

The Unique bedside table with two drawers and gola handle is in Cenere finish.





Il comò Unique, con tre cassetti e maniglia a gola, è disponibile nella versione con fianchi sottili oppure con fianchi spessi.

The Unique dresser, with three drawers and a gola handle, is available in two version with thin sides or with thick sides.

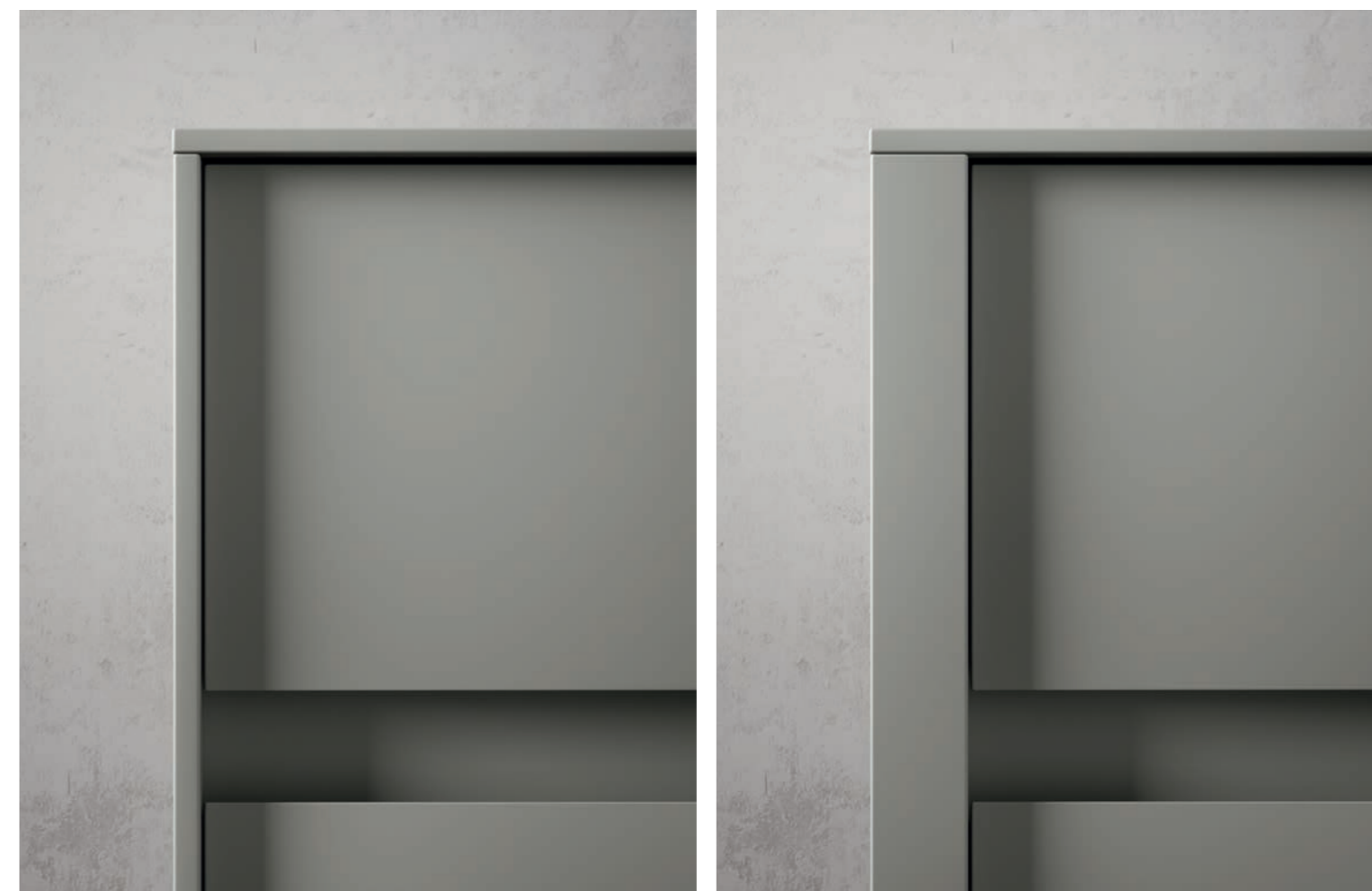

Variante di finitura

In questa variante comodino e comò Unique, nella versione con fianco spesso, hanno frontali in finitura laccato Fondente e fianchi in finitura Testa di moro.

Finishing variant

In this variant: Unique bedside table and dresser; in the version with thick side, they have fronts in lacquered Fondente finish and sides in Testa di Moro finish.



LETTO CLOUD
COMODINO E CASSETTIERA STREAM

Linee semplici e lineari dalle forme morbide e accattivanti: un letto con una forte carica immaginativa ed espressiva, capace di rispondere ai nostri desideri interiori di tranquillità e benessere.

Un letto che racconta una storia molto personale: il nostro modo di intendere la casa e la vita.

Simple and linear lines with soft and attractive shapes: a bed with a strong imaginative and expressive charge, able to respond to our inner desires of tranquility and well-being.

A bed that tells a very personal story: our way to understand home and life.





Il letto Cloud con testiera imbottita e rivestita in tessuto Beatrice BB01 è abbinata al giroletto h. 28,4 cm.

The Cloud bed with covered and upholstered headboard in Beatrice BB01 fabric is combined with h. 28,4 cm bedframe.







La cassettera e il comodino Stream sono presentati in finitura laccato Selva con maniglia laccata Selva.

Stream chest of drawers and bedside table are presented in lacquered Selva finish with lacquered Selva handle.



LETTO CLOUD
COMODINO E CASSETTIERA LOOP

Gli oggetti che noi scegliamo per arredare il nostro spazio notte esprimono sempre una visione progettuale personale. In questa composizione, la scelta del letto, dei comodini e del comò rimanda al desiderio di far convivere morbidezza e razionalità, in un contrasto che è interpretabile come una profonda ricerca di equilibrio.

The objects we choose for furnish our sleeping space always express a personal design vision. In this composition, choice of bed, of the bedside tables and dresser expresses the desire to live softness and rationality together, in a contrast that can be interpreted as a profound research for balance.









La testiera imbottita Cloud è rivestita in tessuto Bianca BA09. Anche il giroletto h. 28,4 cm è in tessuto Bianca BA09.

Comodini e cassetiera Loop hanno struttura e frontali dei cassetti in finitura Fango con dettagli interni in finitura Canvas. L'interessante disegno geometrico dei frontali, oltre che dare valore estetico, ha funzione di maniglia.

The Cloud upholstered headboard is covered in Bianca BA09 fabric. Also the h. 28.4 cm bedframe is covered in Bianca BA09 fabric.

Loop bedside tables and chest of drawers have structure and fronts of the drawers in Fango finish with interior details in Canvas finish. The interesting geometrical drawing of the fronts as well as giving aesthetic value, has the function of handle.



LETTO CLOUD
COMODINO E SETTIMINO STREAM

Come una nuvola il letto Cloud porta la morbidezza nell'ambiente notte. La testiera sagomata e imbottita trasforma l'ambiente notte in un angolo accogliente e rilassante.

Like a cloud, the Cloud bed brings the softness to the night environment. The shaped and upholstered headboard turns the night environment into a cozy and relaxing corner.





La testiera imbottita Cloud con bordo pizzicato in queste pagine è rivestita in tessuto Ada AA07.

Cloud upholstered headboard with pinched edge in these pages is covered in Ada AA07 fabric.



**Varianti giroletti**

Nella pagina a fianco: variante del letto Cloud con giroletto Stilo in finitura Testa di moro e piedino in Ghisa.

In questa pagina: a sinistra dettaglio del giroletto Step e a destra dettaglio del giroletto Vip.

Beds variants

On the next page: variant of Cloud bed with Stilo bedframe in Testa di Moro finish and Ghisa foot.

On this page: on the left Step bedframe detail and on the right Vip bedframe detail.



Il comodino e il settimino Stream, nella versione con pratici vani a giorno, sono raffigurati in finitura Testa di moro con dettagli in finitura laccato Tirreno.

Stream bedside table and septet, in the version with practical open compartments, are depicted in Testa di Moro finish with details in lacquered Tirreno finish.



LETTO CHLOE
GRUPPO NOTTE ARIA

Un oggetto con un disegno di forte identità che risponde al nostro desiderio morbidezza e alla nostra voglia di piacere e di riposo. Una testiera alta e morbida, baricentro visivo dalla forma trapezoidale, rivestita in tessuto e caratterizzata da un cordonetto come segno di contrasto. Un'eleganza estetica completata dalla razionalità del gruppo, con moduli sovrapposti.

An object with a strong identity design that responds to our softness desire and to our desire for pleasure and rest. A high and soft headboard, visual center of gravity from the trapezoidal shape, covered in fabric and characterized by a cord as a sign of contrast. A aesthetic elegance completed by the rationality of the group, with overlapping modules.









Il letto imbottito Chloe è rivestito in tessuto Beatrice BB03 con cordonetto a contrasto in tessuto Barbara BC02.

I comodini asimmetrici sono realizzati con moduli componibili Aria in finitura laccata Argilla e Canvas con maniglia in finitura Argilla.

Chloe upholstered bed is covered in Beatrice BB03 fabric with contrasting cord in Barbara BC02 fabric.

The asymmetric bedside tables are made with Aria modular units in lacquered Argilla and Canvas finish with handle in Argilla finish.

La cassetiera è composta da moduli sfalsati Aria in finitura laccata Argilla e Canvas, con maniglia in finitura Argilla.

The chest of drawers is composed from Aria staggered modules in lacquered Argilla and Canvas finish, with handle in Argilla finish.



LETTO CHLOE
COMODINO E COMÒ CUBE

Un contrasto di linee, quelle morbide e arrotondate del letto Chloe, con la sua testiera a trapezio, e quelle più lineari e razionali del gruppo notte Cube.

A contrast of lines, the soft and rounded ones of the Chloe bed, with its trapezoidal headboard, and the more linear and rational ones of the Cube night group.







Il letto Chloe con giroletto h. 28,4 cm è rivestito in tessuto Beatrice BB01 con cordonetto a contrasto in ecopelle Barbara BC06.

Chloe bed with h. 28,4 cm bedframe is covered in Beatrice BB01 fabric with Barbara BC06 contrasting eco-leather cord.





Cassettiera e comodino Cube con fianchi Slim hanno frontali in finitura Canvas, mentre maniglie e scocca sono in finitura Fango.

Cube chest of drawers and bedside table with Slim sides have fronts in Canvas finish, while handles and shell are in Fango finish.



Letti contenitore
Container beds

Letti imbottiti disponibili con contenitore
Upholstered beds available with container



Rubik



Cloud



Cloé



Wave

Giroletti disponibili con contenitore
Bedframes available with container



Giroletto h. 28,4 cm per testiere modulari
H. 28,4 cm bedframe for modular headboards

Meccanismi di apertura Opening mechanisms



Letto contenitore con apertura frontale
Container bed with front-flap opening



Letto contenitore con apertura Easy-Up
Container bed with Easy-Up opening

Letti in legno disponibili con contenitore Beauty
Wooden beds available with Beauty container



Sommier su testiere:
Modula, Carrè, Side



Sirio



Blade

Giroletti disponibili con contenitore Beauty
Bedframes available with Beauty container



Step



Vip



Stilo

Contenitore Beauty
Beauty container



Contenitore Beauty
Beauty container



Il contenitore Beauty si apre con meccanismo alzante ed è dotato di illuminazione LED opzionale.

The Beauty container opens with lifting mechanism and is equipped with optional LED lighting.

Informazioni tecniche
Technical information

Sistema testiera
Headboard system
Modula

Testiera composta da moduli in legno o imbottiti di diverse altezze e larghezze. Retroilluminazione opzionale.

Headboard composed of wooden or upholstered modules of different heights and widths. Optional back lighting.



Profondità testiera (con pannelli legno)
Headboard depth (with wooden panels)

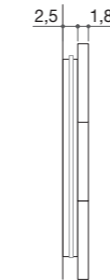

Profondità testiera (con pannelli imbottiti)
Headboard depth (with upholstered panels)



Profondità testiera legno più giroletto 3 lati
Wooden headboard depth + 3 sides bedframe

Vip cm 4,3 + 206,6
Step cm 4,3 + 206,6
Stilo cm 4,3 + 206,6
Sommier h 14 cm 4,3 + 205,8
Sommier h 28,4 cm 4,3 + 205,8

Pannello legno
Wooden panel



Pannello imbottito sfoderabile
Upholstered panel with removable cover



Accessori / Accessories

Mensola T in metallo
solo per pannelli intermedi
Metal T-shaped shelf only for intermediate panels

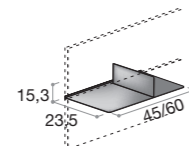

Kit luci LED disponibili
Available LED light kit

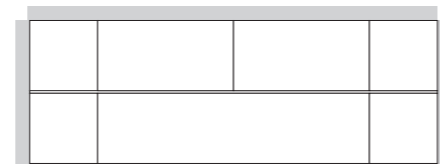

3 lati - 3 sides
2 lati - 2 sides
Lato superiore - Superior side

Comodino sospeso
Suspended bedside table

Gruppo Fly vedi pag. 236

Mensola in metallo
solo per pannello superiore
Metal shelf only for superior panel

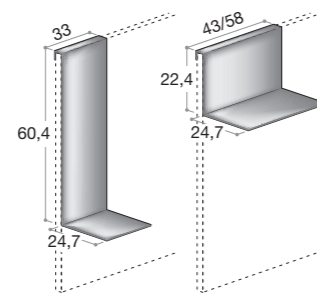

Mensola in metallo rivestito
in pannelli solo per pannello superiore
Covered metal shelf in panels (only for top panel)

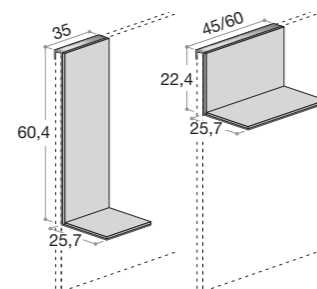

Finiture / Finishes

Testiera / Headboard
Nobilitati F1 - Melamine F1
Laccati LA - Lacquered LA
Tessuti - Fabrics

Configurazioni
Setups

Versione sospesa simmetrica
Floor standing symmetrical version

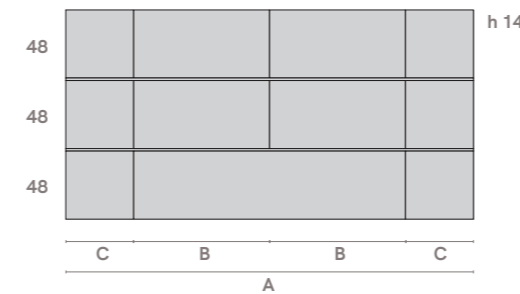

Versione sospesa asimmetrica
Floor standing asymmetrical version

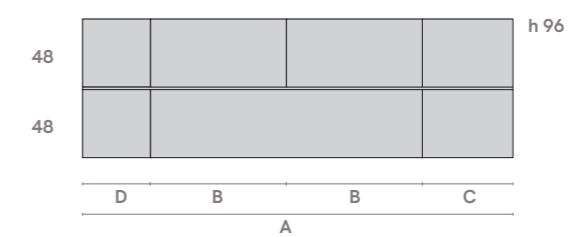
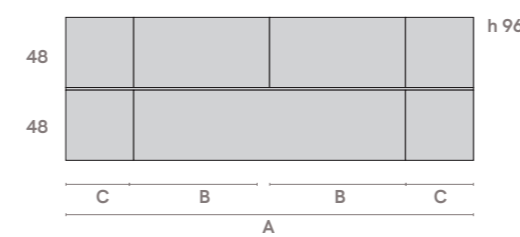
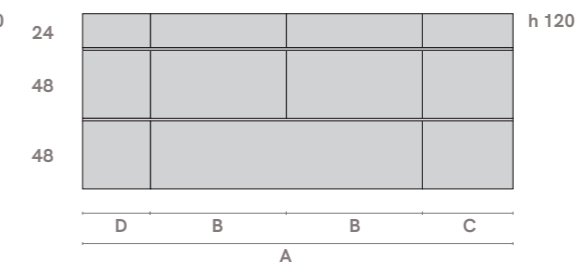
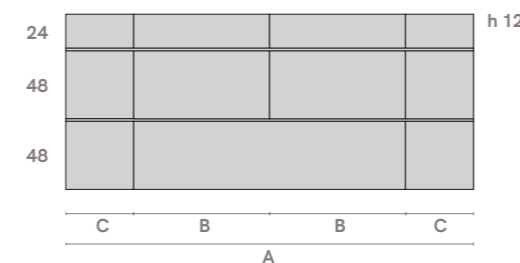
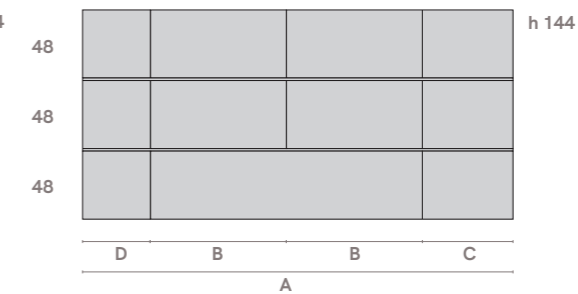

Versione sospesa simmetrica
Suspended symmetrical version

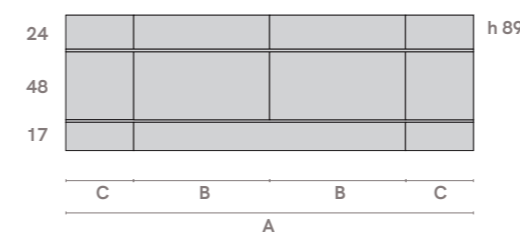

Versione sospesa asimmetrica
Suspended asymmetrical version

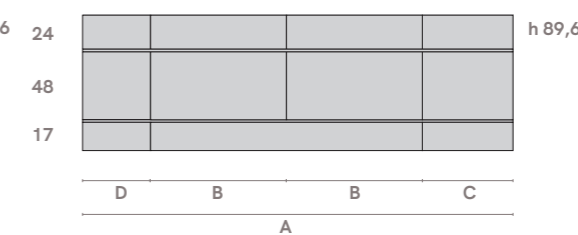

Simmetrica / Symmetrical

Dimensione Dimension	Dimensione pannelli Panels dimension	
A	B	C
270	90	45
300	90	60
360	90	90
290	100	45
320	100	60
380	100	90

Asimmetrica / Asymmetrical

Dimensione Dimension	Dimensione pannelli Panels dimension			
A	B	C	D	
285	90	60	45	
315	90	90	45	
330	90	90	60	
305	100	60	45	
335	100	90	45	
350	100	90	60	

Sistema testiera Headboard system Carrè

Testiera composta da pannello singolo o pannelli multipli in varie configurazioni. Retroilluminazione o illuminazione integrata opzionale.

Headboard composed of single panel or multiple panels in various setups. Optional backlight or integrated lighting.



Profondità testiera Headboard depth

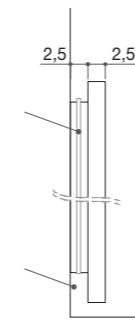

Profondità testiera più giroletto 3 lati Headboard depth + 3 sides bedframe

Vip	cm 5 + 206,6
Step	cm 5 + 206,6
Stilo	cm 5 + 206,6
Sommier h 14	cm 5 + 205,8
Sommier h 28,4	cm 5 + 205,8

Particolare profilo metallo Metal profile detail



Accessori / Accessories

Kit luci LED disponibili
Available LED light kit

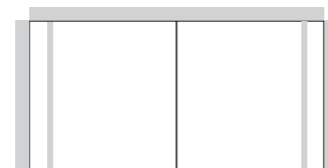

Frontale - Front
Lato superiore - Superior side
Laterale 2 lati - Lateral 2 sides
3 lati - 3 sides

Comodini sospesi
Suspended bedside table

Gruppo Fly vedi pag. 236
Gruppo Aria vedi pag. 228, 230

Configurazioni testiera Headboard setups

1 pannello / 1 panel



2 pannelli / 2 panels

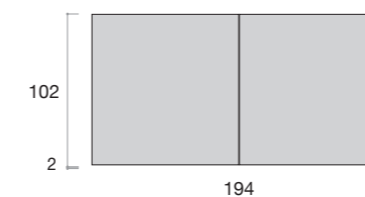

3 pannelli / 3 panels

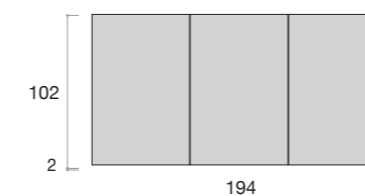

Configurazioni testiera + pannelli laterali Headboard setups + lateral panels

3 pannello / 3 panels

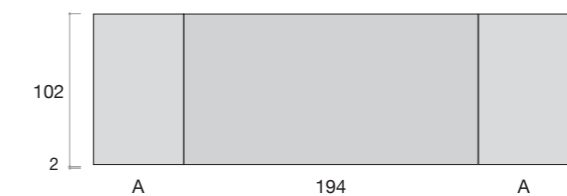

4 pannelli / 4 panels

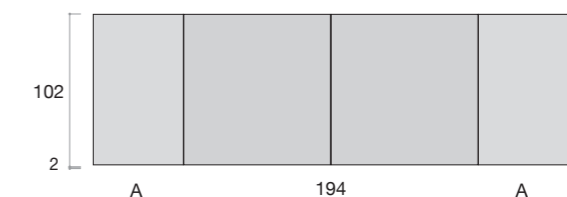

5 pannelli / 5 panels

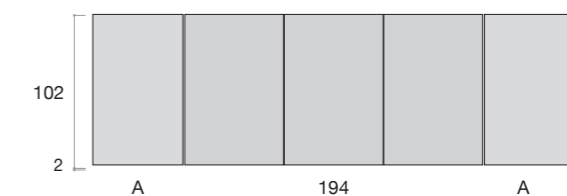

Particolare LED frontale Front Led detail



Finiture / Finishes

Testiera / Headboard
Nobilitati F1 - Melamine F1
Laccati LA - Lacquered LA

**Profili divisorii testiera /
Headboard partition sides profiles**
Metallo laccato - Ghisa, Platino
Lacquered metal - Ghisa, Platino

Orientamento finitura / Finishing direction

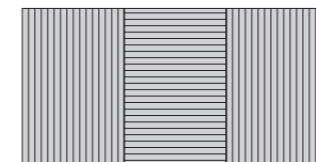

Possibilità di scelta di orientamento verticale o orizzontale della venatura di ogni pannello. Solo per i nobilitati Alaska, Frassino Normandie, Natura, Rovere Caramel, Testa di moro e Cannetè.

Possibility of choice of vertical or horizontal grain direction for each panel. Only available for melamine Alaska, Frassino Normandie, Natura, Rovere Caramel, Testa di Moro and Cannetè.

Dimensione pannelli laterali A Lateral panels dimension A

45
50
60
75
90
100

Sistema testiera
Headboard system
Side

Testiera composta da uno o due moduli in legno (simmetrici o asimmetrici). Retroilluminazione opzionale.

Headboard composed of one or two wooden modules (symmetrical or asymmetrical). Optional backlight.



Profondità testiera
Headboard depth

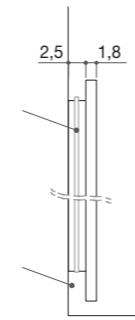

Profondità testiera più giroletto 3 lati
Profondità testiera più giroletto 3 lati

Vip	cm 4,3 + 206,6
Step	cm 4,3 + 206,6
Stilo	cm 4,3 + 206,6
Sommier h 14	cm 4,3 + 205,8
Sommier h 28,4	cm 4,3 + 205,8

Particolare testiera imbottita
Upholstered headboard detail



Accessori / Accessories

Testiera imbottita sfoderabile
Removable upholstered headboard

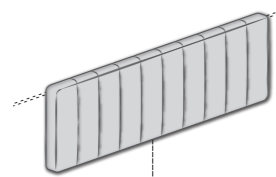

Largh.
Width

- 128,8
- 161,8
- 168,8
- 188,8

Kit luci LED disponibili
Available LED light kit

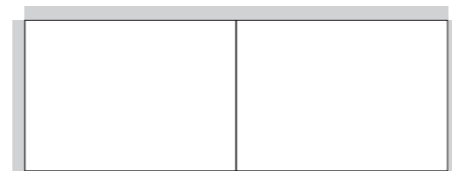

- 3 lati - 3 sides
- 2 lati - 2 sides
- Lato superiore - Superior side

Comodini sospesi
Suspended bedside tables

Gruppo Fly vedi pag. 236
Gruppo Aria vedi pag. 228, 230

Mensola in metallo
Metal shelf

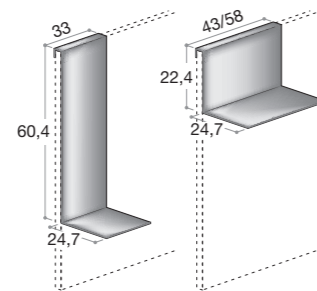

Mensola in metallo con pannelli
Metal shelf with panels

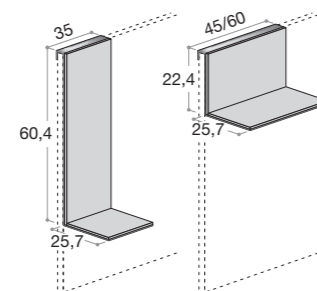

Finiture / Finishes

Testiera / Headboard
Nobilitati F1 - Melamine F1
Laccati LA - Lacquered LA

Configurazioni
Setups

Simmetrica / Symmetrical

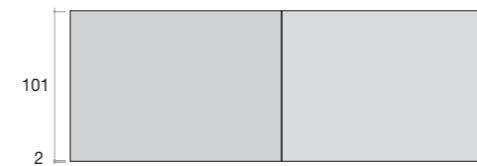

Dimensione
Dimension

- 280
- 300
- 320
- 340
- 360

Dimensione pannelli
Panels dimension

- 140+140
- 150+150
- 160+160
- 170+170
- 180+180

Asimmetrica / Asymmetrical



Dimensione
Dimension

- 280
- 280
- 290
- 290
- 300
- 300
- 300
- 310
- 310
- 310
- 310
- 320
- 320
- 320
- 330
- 330
- 330
- 340
- 340
- 350
- 360

Dimensione pannelli
Panels dimension

- 150+130
- 160+120
- 150+140
- 160+130
- 170+120
- 160+140
- 170+130
- 180+120
- 160+150
- 170+140
- 180+130
- 190+120
- 170+150
- 180+140
- 190+130
- 170+160
- 180+150
- 190+140
- 180+160
- 190+150
- 190+160
- 190+170

Pannello unico / Single panel

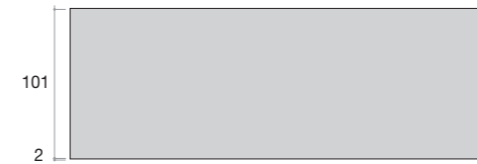

Dimensioni
Dimension

- 280
- 290
- 300

Disponibile anche taglio su misura
Custom cutting available

Giroletti per sistemi Modula - Side - Carrè Modula - Side - Carré system bedframes

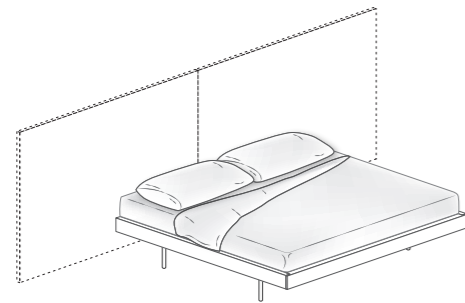

Tutti i modelli sono disponibili anche in versione 4 lati.

All models are available also in 4 sides version.

Tipologie giroletto in legno Wooden bedframe typologies



Step

Vip

Stilo

Contenitore alzante / Lift-up container Disponibili per giroletti Step, Vip, Stilo Available for Step, Vip and Stilo bedframes



Beauty

Finiture / Finishes

Giroletto legno / Wooden bedframe

Nobilitati F2 (Step-Vip) - Melamine F2 (Step-Vip)
Nobilitati F1 (Stilo) - Melamine F1 (Stilo)
Laccati - Lacquered

Giroletto imbottito / Upholstered bedframe

Tessuto - Fabric
Ecopelle - Eco-leather

Piedini / Feet

Cilindro: Ghisa
Forma, Cono, Prisma: Ghisa, Platino
Plexi: Transparent plexiglass
Stilo: Ghisa, Platino

Piedini / Feet

Disponibili per giroletti Step, Vip, Imbottito h. 14 cm
Available for Step, Vip and h. 14 cm upholstered bedframes



Cilindro

Forma

Plexi

Profondità giroletto 3 lati 3 sides bedframe depth

Vip	cm 206,6
Step	cm 206,6
Stilo	cm 206,6
Sommier h. 14	cm 205,8
Sommier h. 28,4	cm 205,8

Profondità giroletto 4 lati 4 sides bedframe depth

Vip	cm 210,4
Step	cm 210,4
Stilo	cm 210,4
Sommier h. 14	cm 208,8
Sommier h. 28,4	cm 208,8

Tipologie giroletto imbottito Upholstered bedframe typologies



Imbottito h. 14 cm
H. 14 cm upholstered
bedframe

Imbottito h. 28,4 cm
H. 28,4 cm upholstered
bedframe

Piedini opzionali / Optional feet Piedini alza letto (per passaggio robot) Feet for robot passage



Cono

Prisma

Variante rete per giroletto imbottito h. 28,4 cm e Beauty Slatted net variant for h. 28,4 cm upholstered bedframe and Beauty

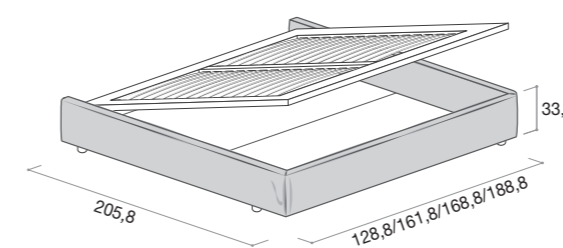

Rete alzante frontale
Front-flap slatted net

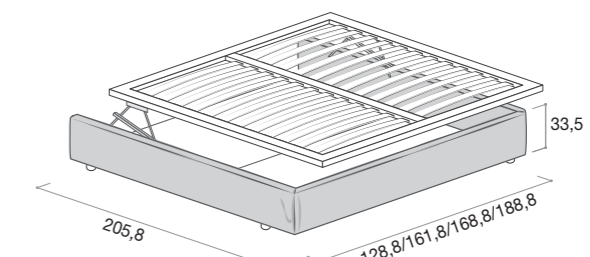

Rete alzante Easy-up (NON disponibile su Beauty)
Easy-up slatted net (NOT available for Beauty)

Sirio

Letto in legno disponibile con testiera composta da uno, quattro o sei moduli.

Wooden bed available with headboard composed of one, four or six modules.



Tipologie testiera / Headboard typologies

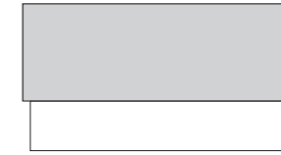

Sirio 1

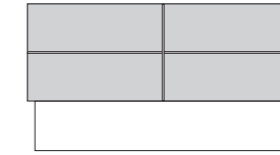

Sirio 4

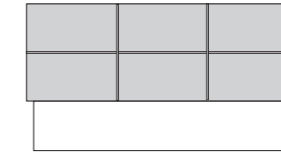

Sirio 6

Particolare testiera / Headboard detail

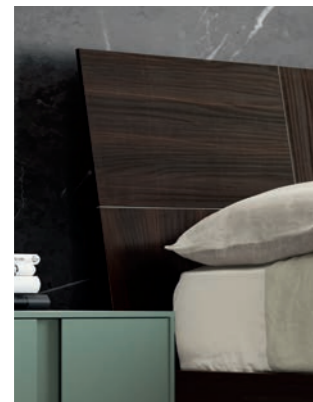

Tipologie giroletto / Bedframe typologies



Step



Vip



Stilo



Beauty

Contenitore alzante / Lift-up container

Disponibili per giroletti Step, Vip, Stilo
Available for Step, Vip and Stilo bedframes

Piedini / Feet

Disponibili per giroletti Step, Vip
Available for Step, Vip bedframes



Cilindro



Forma



Plexi

Finiture / Finishes

Testiera / Headboard

Nobilitati F1 - Melamine F1
Laccati - Lacquered

Giroletto legno / Wooden bedframe

Nobilitati F2 (Step, Vip) - Melamine F2 (Step, Vip)
Nobilitati F1 (Stilo) - Melamine F1 (Stilo)
Laccati - Lacquered

Profili divisori testiera / Headboard partition sides profiles

Metallo laccato: Ghisa, Platino
Lacquered metal: Ghisa, Platino

Piedini / Feet

Cilindro: Ghisa
Forma, Cono, Prisma: Ghisa, Platino
Plexi: Transparent plexiglass

Ingombri e misure letti / Beds dimensions

Con giroletto Vip e Step - With Vip and Step bedframe

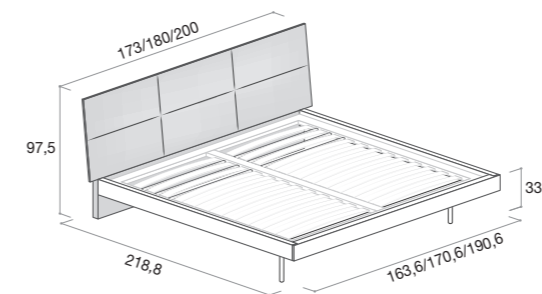

Dim. rete e materasso	Dim. testiera
Slatted net and mattress dim.	Headboard dim.
153 x 200	173
160 x 200	180
180 x 200	200

Con giroletto Vip, Step e cassone Beauty / With Vip and Step bedframe + Beauty container

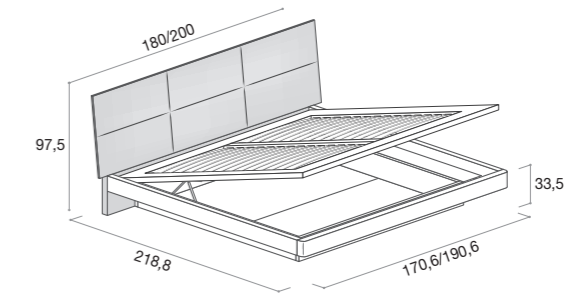

Dim. rete e materasso	Dim. testiera
Slatted net and mattress dim.	Headboard dim.
160 x 200	180
180 x 200	200

Con giroletto Stilo - With Stilo bedframe

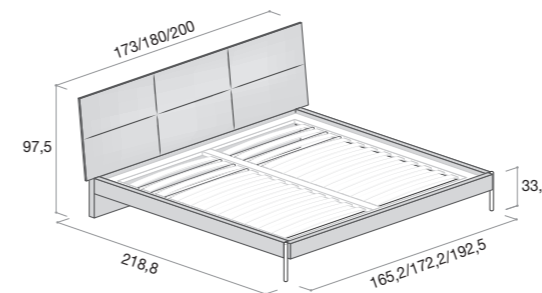

Dim. rete e materasso	Dim. testiera
Slatted net and mattress dim.	Headboard dim.
153 x 200	173
160 x 200	180
180 x 200	200

Con giroletto Stilo e cassone Beauty / With Stilo bedframe and Beauty container

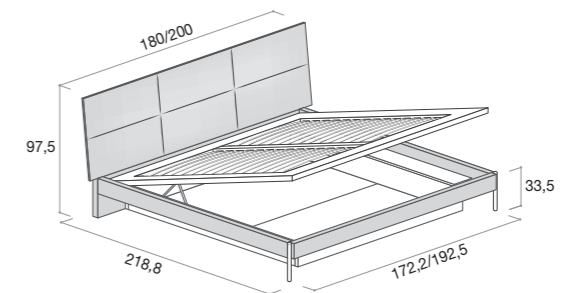

Dim. rete e materasso	Dim. testiera
Slatted net and mattress dim.	Headboard dim.
160 x 200	180
180 x 200	200

Blade

Letto in legno con testiera sospesa, disponibile in tre varianti di testiera.

Wooden bed with suspended headboard available in 3 headboards variants



Tipologie testiera Headboard typologies



Blade Lineare
Straight Blade

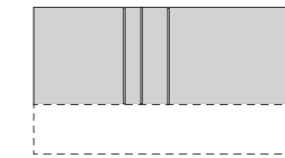

Blade Verticale
Vertical Blade

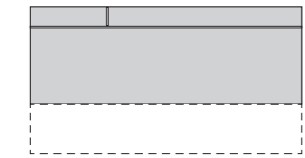

Blade Orizzontale
Horizontal Blade

Particolare testiera Headboard detail



Tipologie giroletto Bedframe typologies



Step



Vip



Stilo



Beauty

Contenitore alzante / Lift-up container Disponibili per giroletti Step, Vip, Stilo Available for Step, Vip and Stilo bedframes

Piedini / Feet Disponibili per giroletti Step, Vip Available for Step, Vip bedframes



Cilindro



Forma



Plexi

Finiture / Finishes

Testiera / Headboard Nobilitati F1 - Melamine F1 Laccati - Lacquered

Giroletto legno / Wooden bedframe Nobilitati F2 (Step, Vip) - Melamine F2 (Step, Vip) Nobilitati F1 (Stilo) - Melamine F1 (Stilo) Laccati - Lacquered

Profili divisori testiera / Headboard partition sides profiles Metallo laccato: Ghisa, Platino Lacquered metal: Ghisa, Platino

Piedini / Feet Cilindro: Ghisa Forma, Cono, Prisma: Ghisa, Platino Plexi: Transparent plexiglass

Ingombri e misure letti Beds dimensions

Con giroletto Vip e Step - With Vip and Step bedframe

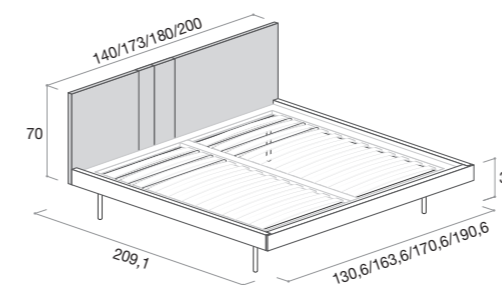

Dim. rete e materasso Slatted net and mattress dim.	Dim. testiera Headboard dim.
120 x 200	140
160 x 200	180
180 x 200	200

Con giroletto Vip, Step e cassone Beauty With Vip and Step bedframe + Beauty container

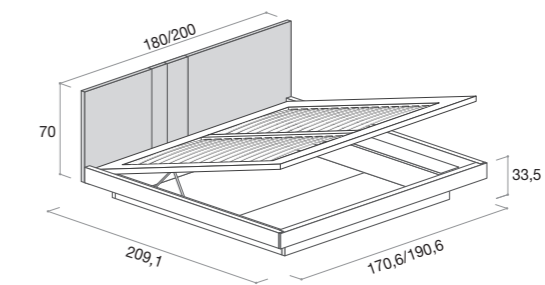

Dim. rete e materasso Slatted net and mattress dim.	Dim. testiera Headboard dim.
160 x 200	180
180 x 200	200

Con giroletto Stilo - With Stilo bedframe

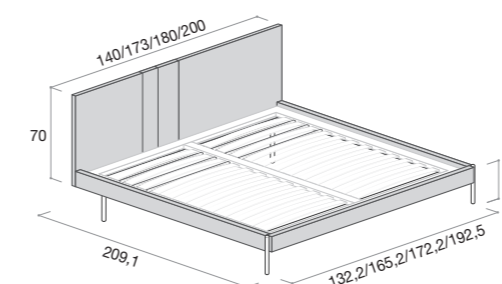

Dim. rete e materasso Slatted net and mattress dim.	Dim. testiera Headboard dim.
120 x 200	140
160 x 200	180
180 x 200	200

Con giroletto Stilo e cassone beauty With Stilo bedframe and Beauty container

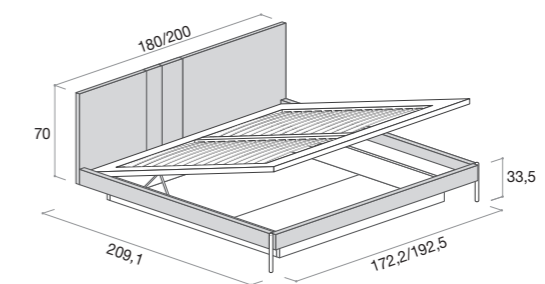

Dim. rete e materasso Slatted net and mattress dim.	Dim. testiera Headboard dim.
160 x 200	180
180 x 200	200

Rubik

Letto imbottito con testiera decorata da lavorazione trapuntata.

Upholstered bed with decorated headboard by quilted workmanship.



Particolare testiera Headboard detail



Doppio colore / cucitura testiera
Double color / headboard seam

Tipologie giroletto Bedframe typologies



Step

Vip

Stilo

Imbottito h. 14 cm Upholstered h. 14 cm

Imbottito h. 28,4 cm Upholstered h. 28,4 cm

Piedini / Feet

Disponibili per giroletti Step, Vip, Imbottito h. 14 cm
Available for Step, Vip, Upholstered h. 14 cm bedframes

Piedini opzionali / Optional feet

Piedini alza letto (per passaggio robot)
Feet for robot passage



Cilindro

Forma

Plexi

Cono

Prisma

Finiture / Finishes

Testiera / Headboard

Tessuto - Fabric
Ecopelle - Eco-leather

Giroletto legno / Wooden bedframe

Nobilitati F2 (Step, Vip) - Melamine F2 (Step, Vip)
Nobilitati F1 (Stilo) - Melamine F1 (Stilo)
Laccati - Lacquered

Giroletto imbottito / Upholstered bedframe

Tessuto - Fabric
Ecopelle - Eco-leather

Piedini / Feet

Cilindro: Ghisa
Forma, Cono, Prisma: Ghisa, Platino
Plexi: Transparent plexiglass

Ingombri e misure letti Beds dimensions

Con giroletto Vip e Step - With Vip and Step bedframe

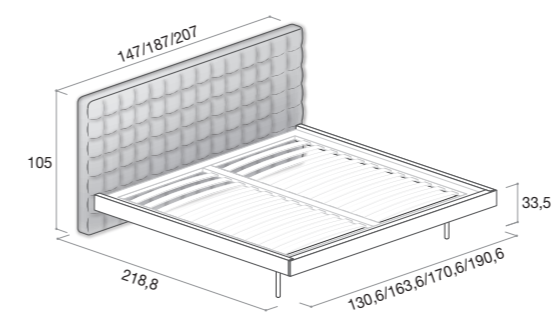

Dim. rete e materasso

Slatted net and mattress dim.
120 x 200
153 x 200
160 x 200
180 x 200

Dim. testiera

Headboard dim.
147
187
187
207

Con giroletto imbottito h. 14 cm e h. 28,4 cm With h. 14 and h. 28,4 cm upholstered bedframe

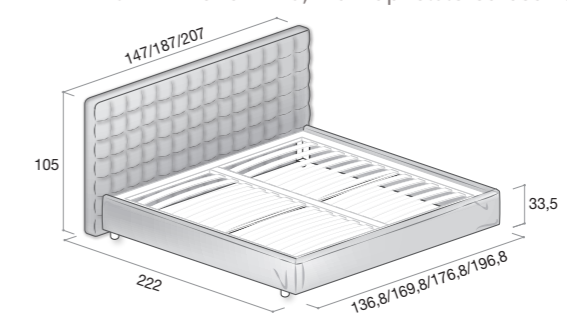

Dim. rete e materasso

Slatted net and mattress dim.
120 x 200
153 x 200
160 x 200
180 x 200

Dim. testiera

Headboard dim.
147
187
187
207

Con giroletto Stilo - With Stilo bedframe

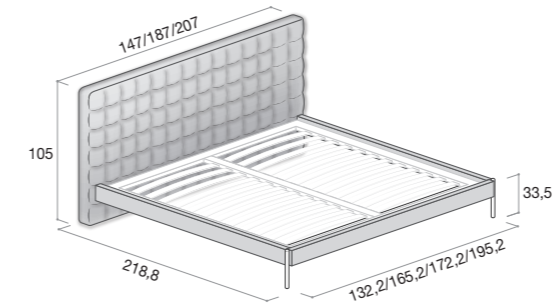

Dim. rete e materasso

Slatted net and mattress dim.
120 x 200
153 x 200
160 x 200
180 x 200

Dim. testiera

Headboard dim.
147
187
187
207

Variante rete per giroletto imbottito h. 28,4 cm Slatted net variant for h. 28,4 cm upholstered bedframe

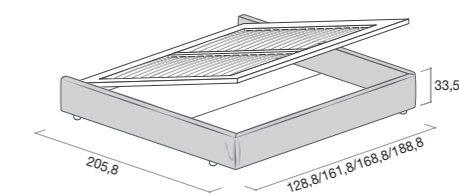

Rete alzante frontale
Front-flap slatted net

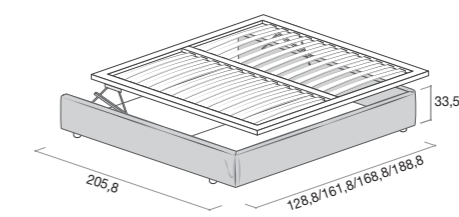

Rete alzante Easy-up
Easy-up slatted net

Cloud

Letto imbottito con testiera composta da due cuscini disponibili con e senza bordo pizzicato.

Upholstered bed with headboard consisting of two cushions available with and without pinched edge.



Particolare testiera Headboard detail



Particolare testiera con tessuto pizzicato Headboard with pinched fabric detail



Tipologie giroletto Bedframe typologies



Step Vip Stilo Imbottito h. 14 cm Upholstered h. 14 cm Imbottito h. 28,4 cm Upholstered h. 28,4 cm

Piedini / Feet
Disponibili per giroletti Step, Vip, Imbottito h. 14 cm
Available for Step, Vip, Upholstered h. 14 cm bedframes

Piedini opzionali / Optional feet
Piedini alza letto (per passaggio robot)
Feet for robot passage



Cilindro Forma Plexi Cono Prisma

Finiture / Finishes

Testiera / Headboard
Tessuto - Fabric
Ecopelle - Eco-leather

Giroletto legno / Wooden bedframe
Nobilitati F2 (Step, Vip) - Melamine F2 (Step, Vip)
Nobilitati F1 (Stilo) - Melamine F1 (Stilo)
Laccati - Lacquered

Giroletto imbottito / Upholstered bedframe
Tessuto - Fabric
Ecopelle - Eco-leather

Piedini / Feet
Cilindro: Ghisa
Forma, Cono, Prisma: Ghisa, Platino
Plexi: Transparent plexiglass

Ingombri e misure letti Beds dimensions

Con giroletto Vip e Step - With Vip and Step bedframe

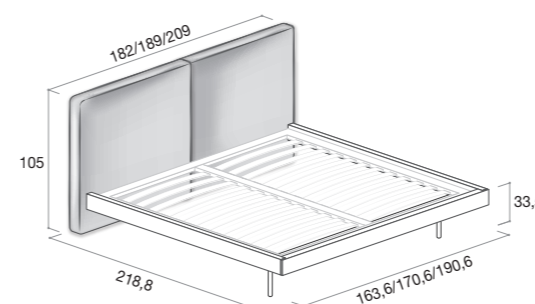

Dim. rete e materasso Slatted net and mattress dim.	Dim. testiera Headboard dim.
153 x 200	182
160 x 200	189
180 x 200	209

Con giroletto imbottito h. 14 cm e h. 28,4 cm With h. 14 cm and h. 28,4 cm upholstered bedframe

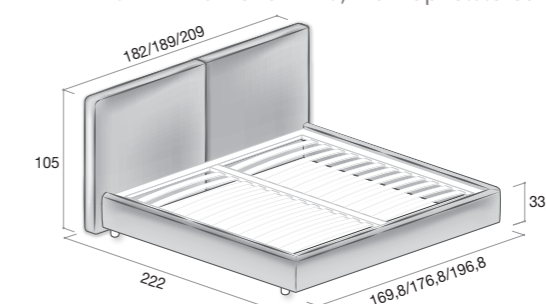

Dim. rete e materasso Slatted net and mattress dim.	Dim. testiera Headboard dim.
153 x 200	182
160 x 200	189
180 x 200	209

Con giroletto Stilo - With Stilo bedframe

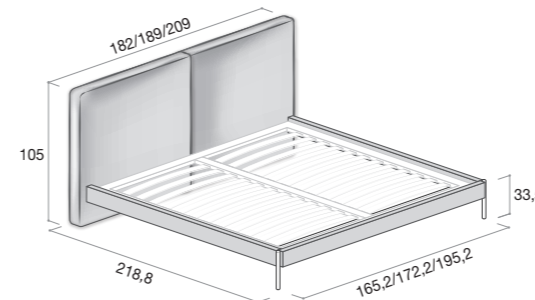

Dim. rete e materasso Slatted net and mattress dim.	Dim. testiera Headboard dim.
153 x 200	182
160 x 200	189
180 x 200	209

Variante rete per giroletto imbottito h. 28,4 cm Slatted net variant for h. 28,4 cm upholstered bedframe

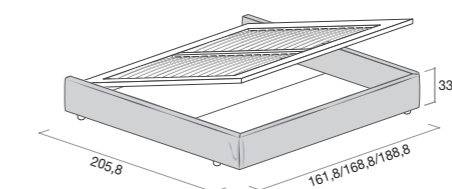

Rete alzante frontale
Front-flap slatted net

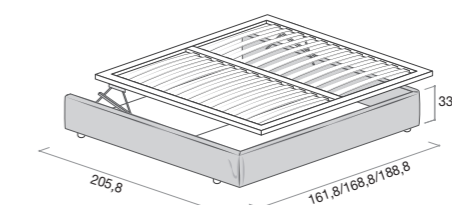

Rete alzante Easy-up
Easy-up slatted net

Chloe

Letto imbottito con testiera a trapezio e bordino in colore a contrasto.

Upholstered bed with trapezoid headboard and contrast edge.



Wave

Letto imbottito con testiera avvolgente.

Upholstered bed with enveloping headboard.



Particolare testiera Headboard detail



Doppio colore / cucitura testiera
Double color / headboard seam

Tipologie giroletto Bedframe typologies



Imbottito h.28,4
Upholstered
h. 28,4 cm

Piedini opzionali / Optional feet
Piedini alza letto (per passaggio robot)
Feet for robot passage



Cono



Prisma

Finiture / Finishes

Testiera / Headboard
Tessuto - Fabric
Ecopelle - Eco-leather

Giroletto imbottito / Upholstered bedframe
Tessuto - Fabric
Ecopelle - Eco-leather

Piedini / Feet
Cono, Prisma: Ghisa, Platino

Ingombri e misure letti Beds dimensions

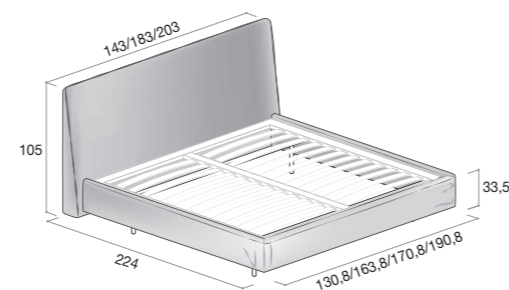

Dim. rete e materasso Slatted net and mattress dim.	Dim. testiera Headboard dim.
120 x 200	143
153 x 200	183
160 x 200	183
180 x 200	203

Variante rete Slatted net variant

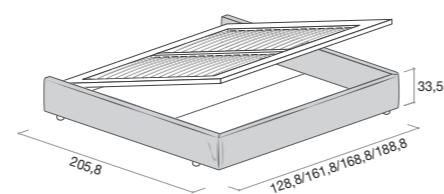

Rete alzante frontale
Front-flap slatted net

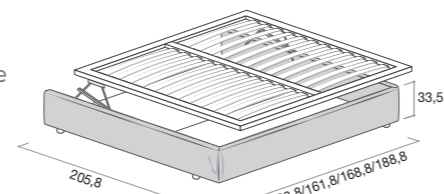

Rete alzante Easy-up
Easy-up slatted net

Particolare testiera Headboard detail



Tipologie giroletto Bedframe typologies



Imbottito h.28,4
Upholstered
h. 28,4 cm

Piedini opzionali / Optional feet
Piedini alza letto (per passaggio robot)
Feet for robot passage



Cono



Prisma

Finiture / Finishes

Testiera / Headboard
Tessuto - Fabric
Ecopelle - Eco-leather

Giroletto imbottito / Upholstered bedframe
Tessuto - Fabric
Ecopelle - Eco-leather

Piedini / Piedini
Cono, Prisma: Ghisa, Platino

Ingombri e misure letti Beds dimensions

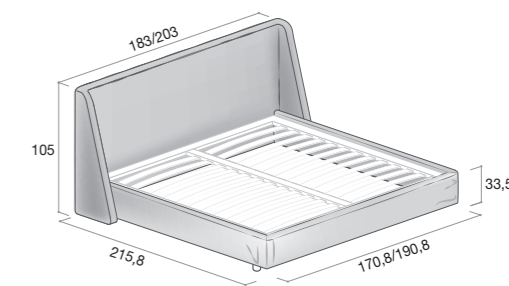

Dim. rete e materasso Slatted net and mattress dim.	Dim. testiera Headboard dim.
160 x 200	183
180 x 200	208

Variante rete Slatted net variant

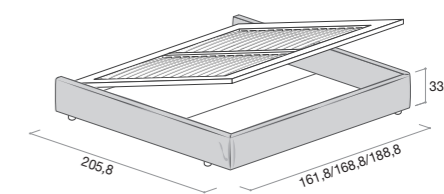

Rete alzante frontale
Front-flap slatted net

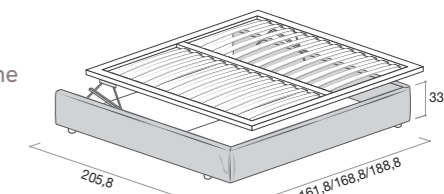

Rete alzante Easy-up
Easy-up slatted net

Aria a terra

Floor standing Aria

Struttura in pannello nobilitato da 18 mm e schiena in pannello nobilitato da 8 mm.
Piedini regolabili h. 17 mm (su elemento a terra).

Cassetto sp.25 mm con guide rallentate.

Top in pannello nobilitato da 10 mm.

Structure in 18 mm melamine panel and back in 8 mm melamine panel.
H. 17 mm adjustable feet (on floor standing element).

Drawer th.25 mm with soft-close runners.

Top in 10 mm melamine panel.



Finiture / Finishes

Struttura / frontale

Structure / front

Nobilitati F1 - Melamine F1
Laccati LA - Lacquered LA

Top

Top

Nobilitati F1 - Melamine F1
Laccati LA - Lacquered LA

Maniglia

Handle

Maniglia Row lunghezza metà frontale, disponibile senza maggiorazione in colore Bianco e Ghisa, disponibile nei colori laccati con maggiorazione.

Row handle half front length, available without surcharge in Bianco and Ghisa color; available in lacquered colors with increase.

Particolare maniglia

Handle detail



Aria a terra

Floor standing Aria

Comodino - Bedside table

P. 46,9 - D. 46,9

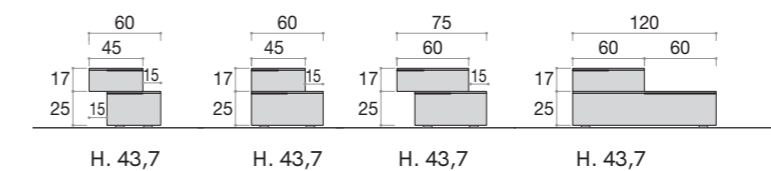

Comò - Dresser

P. 53,3 - D. 53,3

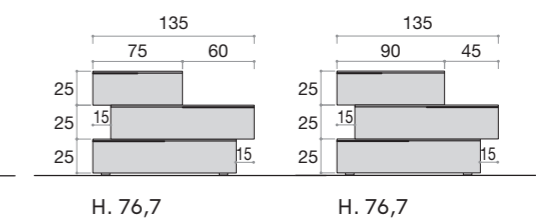

Comò - Dresser

P. 53,3 - D. 53,3

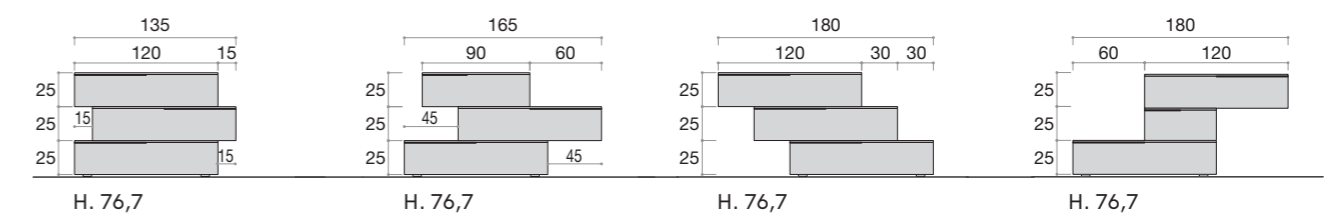

Aria sospeso Suspended Aria

Struttura in pannello nobilitato da 18 mm e schiena in pannello nobilitato da 8 mm.
Piedini regolabili h. 17 mm (su elemento a terra).

Elementi sospesi dotati di attaccaglie per fissaggio a muro o pannello.

Cassetto sp. 25 mm con guide rallentate.

Top in pannello nobilitato da 10 mm.

Structure in 18 mm melamine panel and back in 8 mm melamine panel.
h. 17 mm adjustable feet (on floor standing element).

Suspended elements fitted with hangers for wall or panel fixing.

Drawer th.25 mm with soft-close runners.

Top in 10 mm melamine panel.



Finiture / Finishes

Struttura / frontale Structure / front

Nobilitati F1 - Melamine F1
Laccati LA - Lacquered LA

Top Top

Nobilitati F1 - Melamine F1
Laccati LA - Lacquered LA

Maniglia Handle

Maniglia Row lunghezza metà frontale, disponibile senza maggiorazione in colore Bianco e Ghisa, disponibile nei colori laccati con maggiorazione.

Row handle half front length, available without surcharge in Bianco and Ghisa color; available in lacquered colors with increase.

Particolare maniglia Handle detail



Aria sospeso Suspended Aria

Comò - Dresser P. 53,3 - D. 53,3

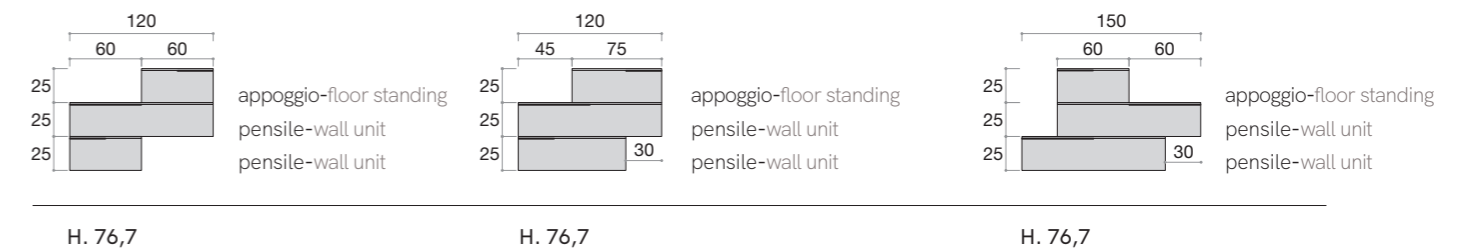

Comò - Dresser P. 53,3 - D. 53,3

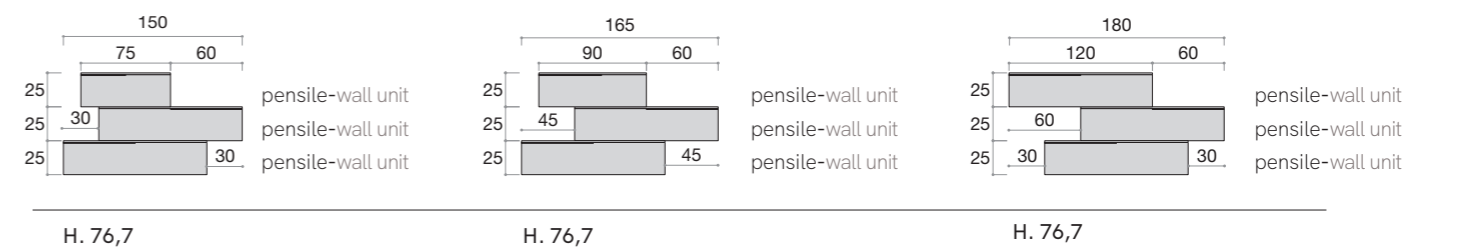

Code

Struttura in pannello nobilitato da 18 mm e schiena in pannello nobilitato da 8 mm.
Cassetto con guide rallentate.
Basamento in metallo verniciato, dotato di piedino regolabile da 10 mm.

Top in pannello nobilitato da 10 mm. Con maggiorazione è disponibile in vetro da 8 mm e in ceramica da 6 mm.

Frontale cassetto in pannello nobilitato da 10 mm.

Structure in 18 mm melamine panel and back in 8 mm melamine panel.

Drawer with soft-close runners.
Base in painted metal, equipped with 10 mm adjustable foot.

Top in 10 mm melamine panel. With surcharge is available in 8 mm glass and 6 mm ceramic finishes.

Drawer front in 10 mm melamine panel.



Finiture / Finishes

Struttura / frontale Structure / front

Nobilitati F1 - Melamine F1
Laccati LA - Lacquered LA

Top Top

Nobilitati F1 - Melamine F1
Laccati LA - Lacquered LA
Vetro - Glass
Ceramica - Ceramic

Basamento Base

Laccato Ghisa, Platino
Lacquered Ghisa, Platino

Maniglia Handle

Pannello nobilitato sp. 10 mm applicato al frontale cassetto. Disponibile nelle finiture Nobilitato e Laccato.

Melamine panel th. 10 mm applied to the drawer front. Available in Melamine and Lacquered finishes.

Particolare maniglia Handle detail



Code

Comodino - Bedside table
P. 47,1 - D. 47,1

Comò - Dresser
P. 53,5 - D. 53,5

Settimino - Septet
P. 53,5 - D. 53,5

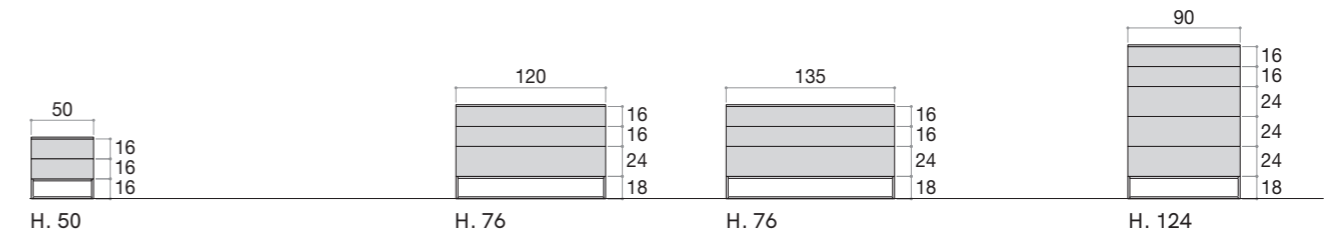

Code con vano a giorno Code with open compartment

Comodino - Bedside table
P. 47,1 - D. 47,1

Comò - Dresser
P. 53,5 - D. 53,5

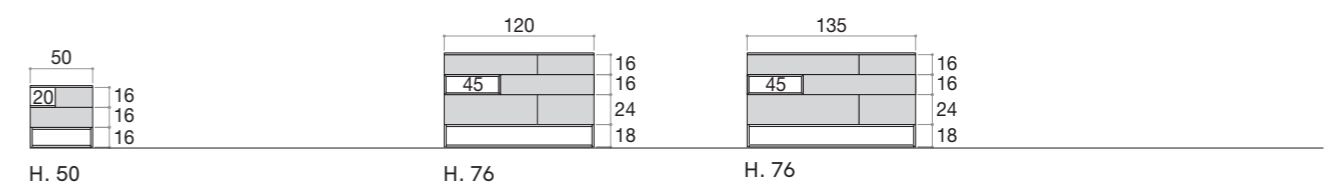

Cube

Struttura in pannello nobilitato da 18 mm e schiena in pannello nobilitato da 8 mm.
Cassetto con guide rallentate.
Piedini regolabili h. 17 mm.

Rivestimento esterno e top in pannello nobilitato da 10 mm.

Frontale cassetto in pannello nobilitato da 18 mm.

Structure in 18 mm melamine panel and back in 8 mm melamine panel.
Drawer with soft-close runners.
h. 17 mm adjustable feet.

External covering and top in 10 mm melamine panel.

Drawer front in 18 mm melamine panel.



Comodino - Bedside table
P. 48,2 - D. 48,2

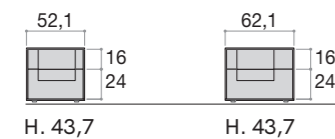

Comò - Dresser
P. 54,6 - D. 54,6

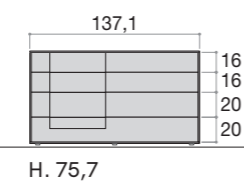
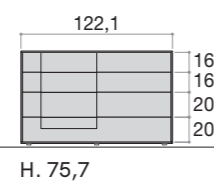

Settimino - Septet
P. 54,6 - D. 54,6

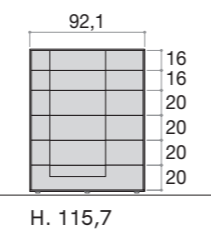

Finiture / Finishes

Particolare maniglia

Handle detail



Struttura

Structure

Nobilitato Titanio
Melamine Titanio

Maniglia

Handle

Pannello MDF da 19 mm, disponibile senza maggiorazione nei colori laccati.

19 mm MDF panel, available without surcharge in lacquered colours.

Rivestimento esterno / frontale / top

External covering / front / top

Nobilitati F1 - Melamine F1
Laccati LA - Lacquered LA

Flat

Struttura in pannello nobilitato da 18 mm e schiena in pannello nobilitato da 8 mm.
Cassetto con guide rallentate.
Piedini regolabili h. 17 mm.

Top in pannello nobilitato da 18 mm.

Structure in 18 mm melamine panel and back in 8 mm melamine panel.
Drawer with soft-close runners.
h. 17 mm adjustable feet.

Top in 18 mm melamine panel.



Comodino - Bedside table
P. 47,8 - D. 47,8

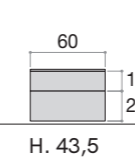
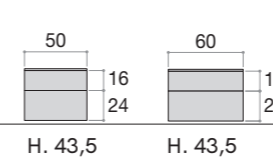
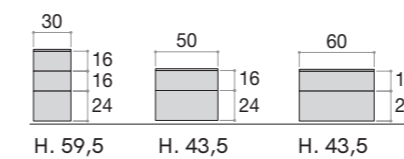

Comò - Dresser
P. 53,8 - D. 53,8

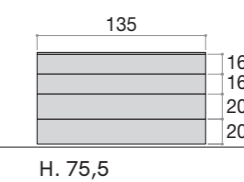
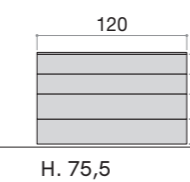

Settimino - Septet
P. 53,8 - D. 53,8

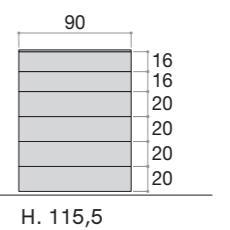

Finiture / Finishes

Particolare maniglia

Handle detail



Struttura / frontale / top

Structure / front / top

Nobilitati F1 - Melamine F1
Laccati LA - Lacquered LA

Maniglia

Handle

Di serie fornito senza maniglia, in quanto il frontale stesso funge da maniglia. Presa laterale in metallo.

Standard supplied without handle, because the front itself acts as handle. Metal lateral grip.

Fly

Struttura in pannello nobilitato da 18 mm e schiena in pannello nobilitato da 8 mm.

Fissaggio a muro o alla testiera del letto tramite attaccaglie regolabili. Cassetto con guide rallentate.

Top in pannello nobilitato da 10 mm. Con maggiorazione è disponibile in vetro da 8 mm e in ceramica da 6 mm.

Structure in 18 mm melamine panel and back in 8 mm melamine panel. Wall or headboard mounting by adjustable hangers. Drawer with soft-close runners.

Top in 10 mm melamine panel. With surcharge is available in 8 mm glass and 6 mm ceramic finishes.

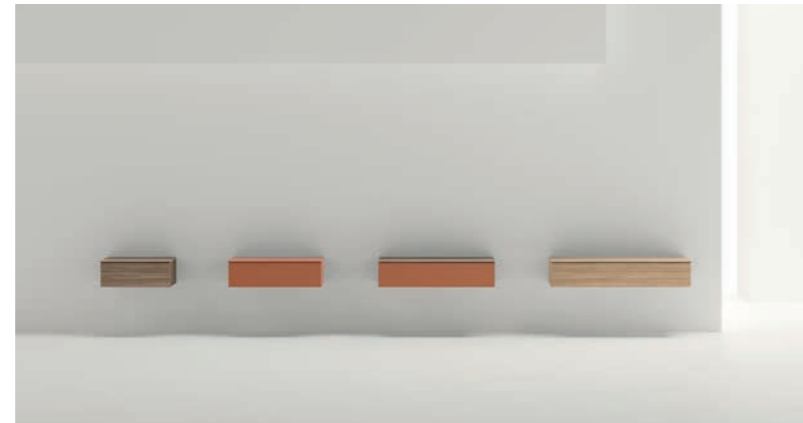

Comodino - Bedside table
P. 46,4 - D. 46,4

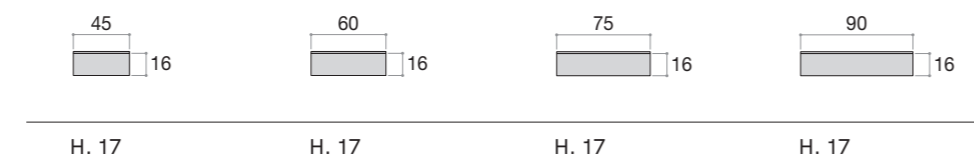

Finiture / Finishes

Struttura / frontale

Structure / front side

Nobilitati - Melamine
Laccati - Lacquered

Top

Top

Nobilitati F1 - Melamine F1
Laccati LA - Lacquered LA
Vetro - Glass
Ceramica - Ceramic

Particolare maniglia

Handle detail



Maniglia

Handle

Di serie fornito senza maniglia (il frontale del cassetto funge da maniglia nella parte inferiore), a richiesta e con maggiorazione disponibile con sistema Push-Pull.

Standard supplied without handle (the front of the drawer acts as handle at the bottom); on request and with surcharge it is available with Push-Pull system.

Groove

Struttura in pannello nobilitato da 18 mm e schiena in pannello nobilitato da 8 mm.

Cassetto con guide rallentate. Piedini regolabili h. 17 mm.

Fianco presa maniglia in pannello nobilitato da 56 mm.

Rivestimento esterno e top in pannello nobilitato da 10 mm.

Frontale cassetto in pannello nobilitato da 18 mm.

Structure in 18 mm melamine panel and back in 8 mm melamine panel. Drawer with soft-close runners. h. 17 mm adjustable feet.

Grip handle side in 56 mm melamine panel.

External covering and top in 10 mm melamine panel.

Drawer front in 18 mm melamine panel.



Comodino - Bedside table
P. 46,4 - D. 46,4

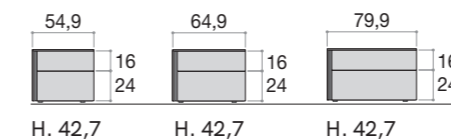

Comò - Dresser
P. 52,8 - P. 52,8

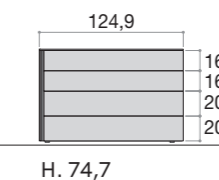

Settimino - Septet
P. 52,8 - D. 52,8

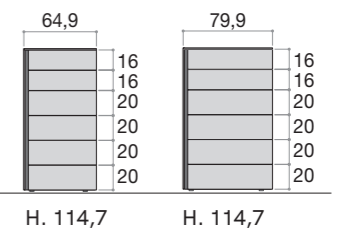

Finiture / Finishes

Struttura

Structure

Nobilitato Titanio
Melamine Titanio

Rivestimento esterno / frontale / top

External covering / front / top

Nobilitati F1 - Melamine F1
Laccati LA - Lacquered LA

Particolare maniglia

Handle detail



Maniglia

Handle

Di serie fornito senza maniglia in quanto il frontale steso funge da maniglia nella parte laterale.

Standard supplied without handle as the front itself acts as handle on the side.

Fianco presa maniglia da 56 mm

56 mm grip handle side

Nobilitato Titanio - Melamine Titanio
Laccati LA - Lacquered LA

Glam

Struttura in pannello nobilitato da 18 mm e schiena in pannello nobilitato da 8 mm.
Cassetto con guide rallentate.
Piedini regolabili h. 17 mm.

Rivestimento esterno e vano a giorno in pannello nobilitato da 10 mm.

Top in pannello nobilitato da 10 mm. Con maggiorazione è disponibile in vetro da 8 mm.

Frontale cassetto in pannello nobilitato da 25 mm.

Structure in 18 mm melamine panel and back in 8 mm melamine panel.
Drawer with soft-close runners.
h. 17 mm adjustable feet.

External covering and open compartment in 10 mm melamine panel.

Top in 10 mm melamine panel.
With surcharge is available in 8 mm glass finish.

Drawer front in 25 mm melamine panel.

Particolare maniglia

Handle detail



Finiture / Finishes

Struttura

Structure

Nobilitato Titanio
Melamine Titanio

Maniglia

Handle

Dotato di serie di Pomolo rigato.
A richiesta e con maggiorazione, può essere fornito con le maniglie riportate a catalogo.

Standard supplied with striped knob.
On request and with surcharge, it can be supplied with the catalogue handles.

Rivestimento esterno / frontale / vano a giorno

External covering / front / open compartment

Nobilitati F1 - Melamine F1
Laccati LA - Lacquered LA

Top

Top

Nobilitati F1 - Melamine F1
Laccati LA - Lacquered LA
Vetro - Glass

Glam

Comodino - Bedside table

P. 49,1 - D. 49,1

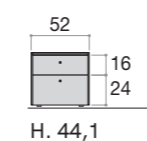

Comò - Dresser

P. 55,5 - D. 55,5

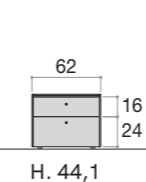

Comò - Dresser

P. 55,5 - D. 55,5

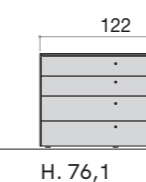

Settimino - Septet

P. 55,5 - D. 55,5

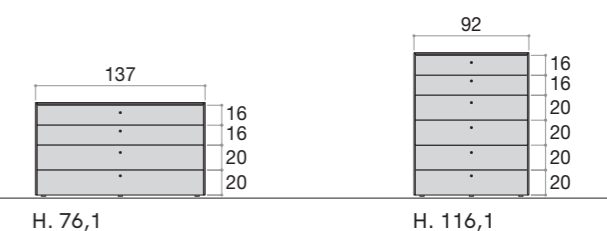

Glam con vano a giorno

Glam with open compartment

Comodino - Bedside table

P. 49,1 - D. 49,1

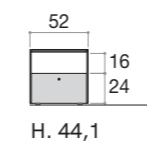

Comò - Dresser

P. 55,5 - D. 55,5

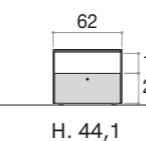

Comò - Dresser

P. 55,5 - D. 55,5

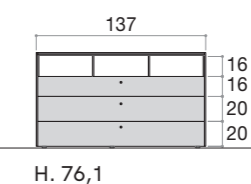
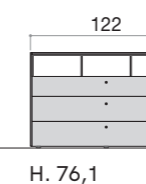

Loop

Struttura in pannello nobilitato da 18 mm e schiena in pannello nobilitato da 8 mm.
Cassetto con guide rallentate.
Piedini regolabili h. 17 mm.

Rivestimento esterno e top in pannello nobilitato da 10 mm.

Frontale cassetto in pannello nobilitato da 18 mm.

Structure in 18 mm melamine panel and back in 8 mm melamine panel.
Drawer with soft-close runners.
h. 17 mm adjustable feet.

External covering and top in 10 mm melamine panel.

Drawer front in 18 mm melamine panel.



Comodino - Bedside table
P. 48,2 - D. 48,2

Comò - Dresser
P. 54,6 - D. 54,6

Settimino - Septet
P. 54,6 - D. 54,6

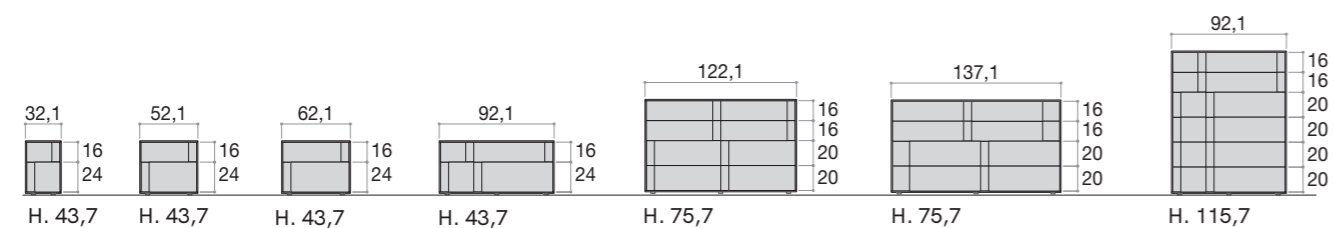

Finiture / Finishes

Struttura

Structure

Nobilitato Titanio
Melamine Titanio

Rivestimento esterno / frontale / top

External covering / front / top

Nobilitati F1 - Melamine F1
Laccati LA - Lacquered LA

Particolare maniglia

Handle detail



Maniglia

Handle

Pannello MDF da 19 mm, disponibile senza maggiorazione nei colori laccati. In fase di montaggio è possibile scegliere l'effetto estetico fornito dalle maniglie: possono essere montate sfalsate (come si vede nelle immagini in alto), tutte allineate a Sx oppure tutte allineate a Dx.

19 mm MDF panel, available without surcharge in lacquered colors. During assembly you can choose the aesthetic effect provided by the handles: they can be mounted staggered (such as can be seen in the images above), all aligned to Left or all aligned to Right.

Polar

Struttura in metallo verniciato.

Piano in pannello nobilitato da 10 mm.

Structure in painted metal.

Top in 10 mm melamine panel.



Comodino - Bedside table
P. 41,4 - D. 41,4

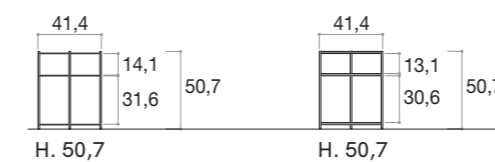

Finiture / Finishes

Struttura metallo

Metal structure

Laccato Ghisa, Platino
Lacquered Ghisa, Platino

Piano

Top

Nobilitati F1 - Melamine F1
Laccati LA - Lacquered LA

Dettaglio piano

Top detail



Stream

Struttura in pannello nobilitato da 18 mm e schiena in pannello nobilitato da 8 mm.
Cassetto con guide rallentate.
Piedini regolabili h. 17 mm.

Rivestimento esterno e vano a giorno in pannello nobilitato da 10 mm.

Top in pannello nobilitato da 10 mm. Con maggiorazione è disponibile in vetro da 8 mm e in ceramica da 6 mm.

Frontale cassetto in pannello nobilitato da 25 mm.

Structure in 18 mm melamine panel and back in 8 mm melamine panel.
Drawer with soft-close runners.
h. 17 mm adjustable feet.

External covering and open compartment in 10 mm melamine panel.

Top in 10 mm melamine panel.
With surcharge is available in 8 mm glass and 6 mm ceramic finishes.

Drawer front in 25 mm melamine panel.



Finiture / Finishes

Struttura Structure

Nobilitato Titanio
Melamine Titanio

Maniglia Handle

Maniglia Row, disponibile senza maggiorazione in colore Bianco e Ghisa, disponibile nei colori laccati con maggiorazione.

Row handle half front length, available without surcharge in Bianco and Ghisa color; available in lacquered colors with increase.

Rivestimento esterno / frontale / vano a giorno External covering / front / open compartment

External covering / front / open compartment

Nobilitati F1 - Melamine F1
Laccati LA - Lacquered LA

Top Top

Nobilitati F1 - Melamine F1
Laccati LA - Lacquered LA
Vetro - Glass
Ceramica - Ceramic

Particolare maniglia Handle detail



Stream

Comodino - Bedside table
P. 49,1 - D. 49,1

Comò - Dresser
P. 55,5 - D. 55,5

Settimino - Septet
P. 55,5 - D. 55,5

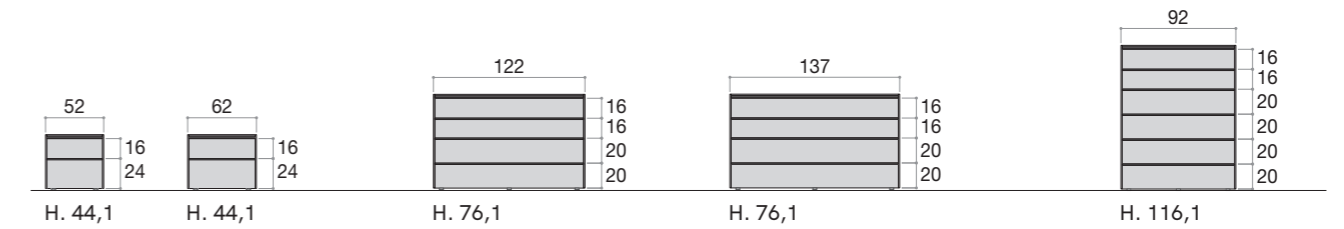

Stream con vano a giorno Stream with open compartment

Comodino - Bedside table
P. 49,1 - D. 49,1

Comò - Dresser
P. 55,5 - D. 55,5

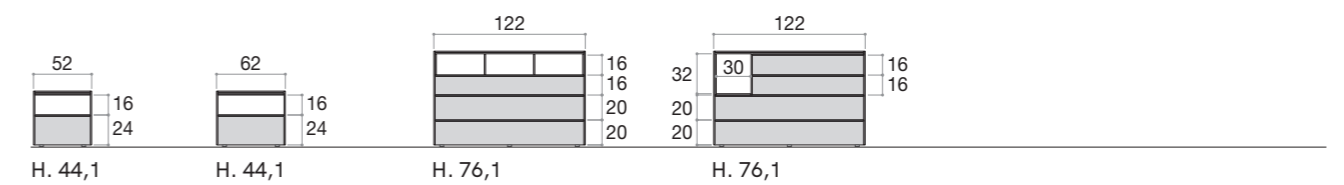

Comò - Dresser
P. 55,5 - D. 55,5

Settimino - Septet
P. 55,5 - D. 55,5

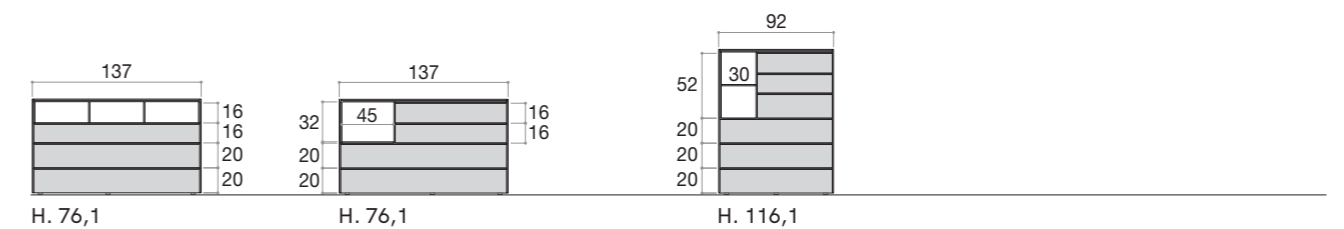

Unique

Struttura in pannello nobilitato da 18 mm e schiena in pannello nobilitato da 8 mm.
Cassetto con guide rallentate.
Piedini regolabili h. 17 mm.

Fianchi
in pannello nobilitato da 10 mm e da 38 mm.

Rivestimento esterno e top
in pannello nobilitato da 10 mm.

Frontale cassetto in MDF con taglio 60°.

Structure in 18 mm melamine panel and back in 8 mm melamine panel.
Drawer with soft-close runners.
h. 17 mm adjustable feet.

Sides in 10 mm and 38 mm melamine panel.

External covering and top in 10 mm melamine panel.

Drawer front in MDF with 60° cut.



Finiture / Finishes

Struttura
Structure

Nobilitato Titanio
Melamine Titanio

Rivestimento esterno
External covering

Nobilitati F1 - Melamine F1
Laccati LA - Lacquered LA

Maniglia
Handle

Di serie fornito senza maniglia in quanto il frontale stesso funge da maniglia.

Standard supplied without handle as the front itself acts as handle.

Frontale cassetto
Drawer front

Laccati LA - Lacquered LA

Particolare maniglia
Handle detail

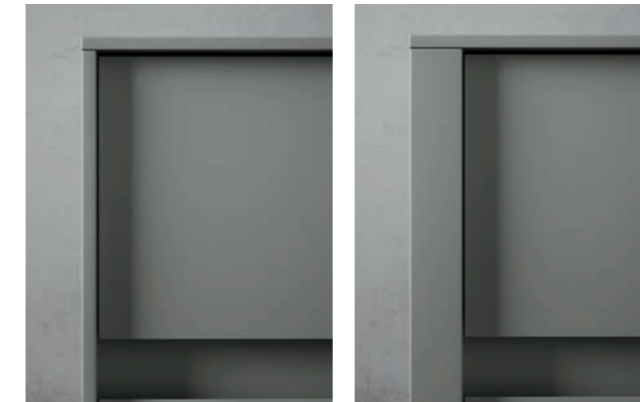

Fianco Unique 10
Unique 10 side

Fianco Unique 38
Unique 38 side

Unique 10

Comodino - Bedside table
P. 48,2 - D. 48,2

Comò - Dresser
P. 54,6 - D. 54,6

Settimino - Septet
P. 54,6 - D. 54,6

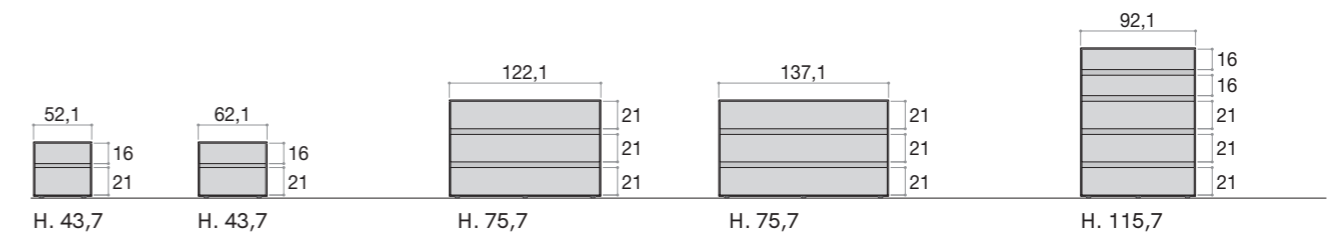

Unique 38

Comodino - Bedside table
P. 48,2 - D. 48,2

Comò - Dresser
P. 54,6 - D. 54,6

Settimino - Septet
P. 54,6 - D. 54,6

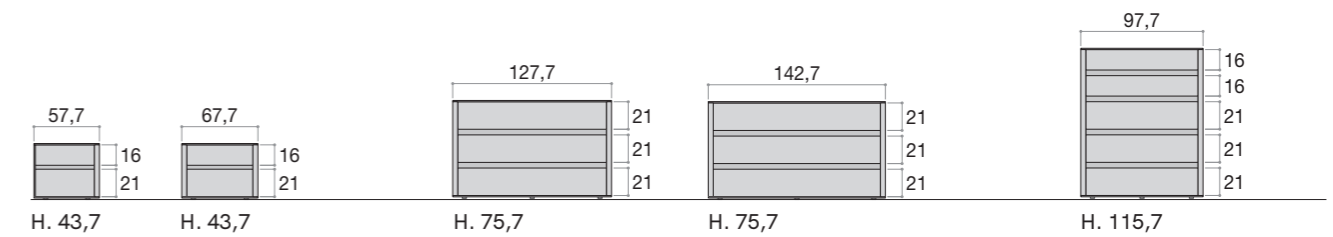

Finiture Finishes

Nobilitati F1 Melamine F1

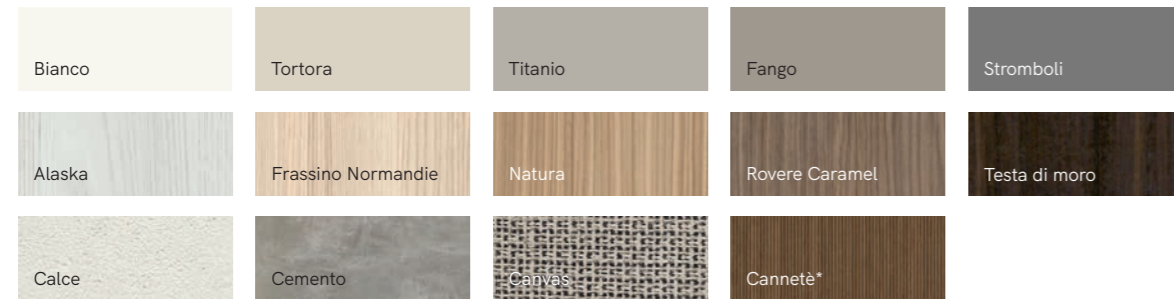

* Disponibile esclusivamente per frontali e testiere Blade, Side, Carrè, Modula
* Only available for fronts and for Blade, Side, Carrè and Modula headboards

Nobilitati F2 per giroletti Vip e Step Melamine F2 for Vip and Step bedframes

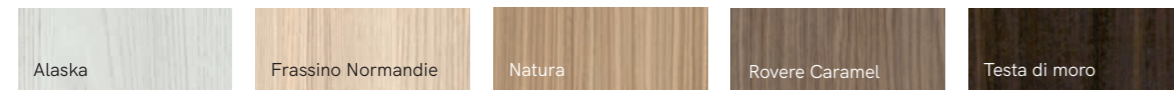

Laccati LA Lacquered LA



Vetri laccati Lacquered glass



Vetro Glass

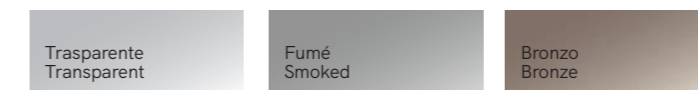

Vetro acidato Etched glass

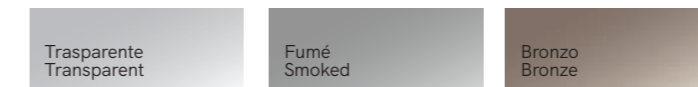

Ceramiche Ceramics

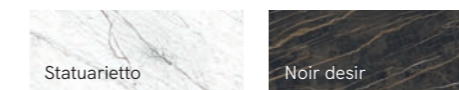

Tappeti Carpets

Tappeto Jacquard Rettangolare Finitura Stromboli



Tappeto con disegno astratto
disponibile nella dimensione
200x280 cm.

Composizione: 85% cotone,
15% poliestere.

Carpet with abstract design
available in 200x280 cm size.

Composition: 85% cotton,
15% polyester.

Tappeto Jacquard Rettangolare Finitura Selva



Tappeto con disegno astratto
disponibile nella dimensione
200x280 cm.

Composizione: 85% cotone,
15% poliestere.

Carpet with abstract design
available in 200x280 cm size.

Composition: 85% cotton,
15% polyester.

Specchiere Mirrors



Specchiera Riflesso Quadrata

Specchio da parete di dimensione 80x80 cm dotato di retroilluminazione LED integrata.

80x80 cm wall mirror equipped with integrated LED backlight.

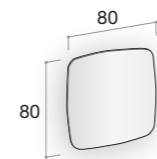

Specchiera Riflesso Rettangolare

Specchio da parete di dimensione 70x180 cm dotato di retroilluminazione LED integrata.

70x180 cm wall mirror equipped with integrated LED backlight.

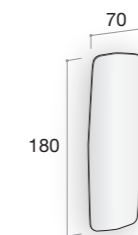



Specchiera Riflesso Cloud

Specchio da parete disponibile nelle dimensioni 90x80 cm e 140x125 cm, con e senza retroilluminazione LED integrata.

Wall mirror available in 90x80 cm and 140x125 cm dimensions, with or without integrated LED backlight.

Cloud



Cloud Riflesso



Coordinati tessili Textile sets

Caratteristiche tecniche Technical characteristics

Copripiumino bicolore (sacco) + federa cuscino bicolore + lenzuolo sotto con angoli monocolori (misura unica per letti L. 120 P. 195/200 cm.) + piumino estivo 100 gr

Two-tone duvet cover (bag) + two-tone pillow case + bed sheet with monochrome corners (single size for L. 120 D. 195/200 cm beds) + 100 gr summer duvet



Combinazioni colore Color combinations



1.
Bianco
Titanio

2.
Stromboli
Tirreno

3.
Cenere
Stomboli

Indice delle composizioni
Composition index

Letti con sistemi testiera / Beds with headboard system



COMP. 01 > PAG 4 Sistema Modula Comodino Fly



COMP. 02 > PAG 14 Sistema Modula Comodino Fly Comò Stream



COMP. 03 > PAG 24 Sistema Modula Comodino Fly



COMP. 04 > PAG 32 Sistema Modula Comodino Fly Vanity Square



COMP. 05 > PAG 40 Sistema Carré Comodino Fly Comodino Polar



COMP. 06 > PAG 52 Sistema Side Comodino Fly Comò Cube



COMP. 07 > PAG 60 Sistema Side Comodino Fly Comodino e cassetiera Code



COMP. 08 > PAG 68 Letto Sirio Comodino e settimino Loop Comodino Polar



COMP. 09 > PAG 82 Letto Sirio Comò e comodini Groove



COMP. 10 > PAG 90 Letto Blade Comò e comodino Flat



COMP. 10 > PAG 98 variante Letto Blade Comodino Aria

Letti in legno / Wooden beds

Letti imbottiti / Upholstered beds

Letti imbottiti / Upholstered beds



COMP. 11 > PAG 102 Letto Wave Gruppo Notte Aria



COMP. 12 > PAG 116 Letto Wave Comodino e cassetiera Stream



COMP. 19 > PAG 180 Letto Chloe Gruppo notte Aria



COMP. 20 > PAG 190 Letto Chloe Comodino e comò Cube



COMP. 13 > PAG 124 Letto Wave Comodino e cassetiera Stream



COMP. 14 > PAG 132 Letto Rubik Comodino e cassetiera Code



COMP. 15 > PAG 142 Letto Rubik Comodino e cassetiera Unique



COMP. 16 > PAG 152 Letto Cloud Comodino e cassetiera Stream



COMP. 17 > PAG 162 Letto Cloud Comodino e cassetiera Loop



COMP. 18 > PAG 170 Letto Cloud Comodino e settimano Stream

Indice letti

Beds index

BLADE

COMP. 10 > **PAG 90**
COMP. 10 var. > **PAG 98**

CARRÈ

COMP. 05 > **PAG 40**

CHLOE

COMP. 19 > **PAG 180**
COMP. 20 > **PAG 190**

CLOUD

COMP. 16 > **PAG 152**
COMP. 17 > **PAG 162**
COMP. 18 > **PAG 170**

MODULA

COMP. 01 > **PAG 4**
COMP. 02 > **PAG 14**
COMP. 03 > **PAG 24**
COMP. 04 > **PAG 32**

RUBIK

COMP. 14 > **PAG 132**
COMP. 15 > **PAG 142**

SIDE

COMP. 06 > **PAG 52**
COMP. 07 > **PAG 60**

SIRIO

COMP. 08 > **PAG 68**
COMP. 09 > **PAG 82**

WAVE

COMP. 11 > **PAG 102**
COMP. 12 > **PAG 116**
COMP. 13 > **PAG 124**

Indice gruppi notte

Night groups index

ARIA

COMP. 10 var. > **PAG 98**
COMP. 11 > **PAG 102**
COMP. 19 > **PAG 180**

CODE

COMP. 07 > **PAG 60**
COMP. 14 > **PAG 132**

CUBE

COMP. 06 > **PAG 52**
COMP. 20 > **PAG 190**

FLAT

COMP. 10 > **PAG 90**

FLY

COMP. 01 > **PAG 4**
COMP. 02 > **PAG 14**
COMP. 03 > **PAG 24**
COMP. 04 > **PAG 32**
COMP. 05 > **PAG 40**
COMP. 06 > **PAG 52**
COMP. 07 > **PAG 60**

GROOVE

COMP. 09 > **PAG 82**

LOOP

COMP. 08 > **PAG 68**
COMP. 17 > **PAG 162**

POLAR

COMP. 05 > **PAG 40**
COMP. 08 > **PAG 68**

STREAM

COMP. 02 > **PAG 14**
COMP. 12 > **PAG 116**
COMP. 13 > **PAG 124**
COMP. 16 > **PAG 152**
COMP. 18 > **PAG 170**

UNIQUE

COMP. 15 > **PAG 142**

La Sostenibilità è più di un solo obiettivo

Sustainability is more than just a goal

La mission sostenibile di Adok adotta un approccio

“design oriented”: termine che indica una naturale e tradizionale attitudine alla progettualità, all'estetica e all'uso creativo oltre che razionale e responsabile delle risorse.

In ogni nostro progetto poniamo in relazione le caratteristiche sensibili del prodotto con le impressioni, le esperienze e le emozioni che può suscitare, per agevolare un legame durevole con chi lo utilizzerà: pensando che è bello, sostenibile, non solo utile. L'idea di design sostenibile perseguita da Adok va oltre quella del puro design di prodotto, e punta a un nuovo design del prodotto/servizio, capace di corrispondere anche ai desideri dell'utente, della società e del “sistema-azienda”.

Adok's sustainable mission adopts a “design oriented” approach: a term that indicates a natural and traditional aptitude for planning, aesthetics and creative use as well as rational and responsible use of resources.

In each of our projects we relate the sensitive characteristics of the product with the impressions, experiences and emotions it can arouse, to facilitate a lasting connection with those who will use it: thinking that it is beautiful, sustainable, not just useful. The idea of sustainable design pursued by Adok goes beyond that of pure product design, and aims at a new product/service design, capable of responding to the wishes of the user, society and the “company-system”.

Un modello di Sostenibilità che trova fondamento in 5 principi cardine:
A model of Sustainability based on 5 key principles:



Ricerca

Essere artefici della Sostenibilità significa sviluppare una ricerca consapevole e responsabile, orientandone gli scopi verso l'adozione di materiali sostenibili e di qualità progettuali.

Research

Being creators of Sustainability means developing conscious and responsible research, directing its purposes towards the adoption of sustainable materials and design quality.



Accoglienza

Progettare spazi accoglienti e realizzare prodotti che trasmettano armonia e comfort, in quanto espressione di scelte responsabili allo stesso tempo verso l'uomo e l'ambiente.

Hospitality

Design welcoming spaces and create products that convey harmony and comfort, as an expression of responsible choices towards both the humankind and the environment.



Trasformabilità

Sviluppare ambienti flessibili e prodotti modulari, che si possano adattare facilmente alle esigenze degli utenti, in simbiosi con bisogni e desideri in trasformazione.

Transformability

Develop flexible environments and modular products, which can be easily adapted to user needs, in symbiosis with changing needs and desires.



Salute

Impiegare materiali e sostanze naturali e sicuri per la salute umana e per l'ambiente, con cicli produttivi a basso impatto ambientale e sicuri per i lavoratori.

Health

Using natural materials and substances that are safe for human health and the environment, with production cycles with low environmental impact and safe for workers.



Cultura

Agire sulla cultura d'impresa e dei consumatori per guidare il comportamento sociale verso un uso più sostenibile dei prodotti e dei servizi.

Culture

Act on corporate and consumer culture to guide social behavior towards a more sustainable use of products and services.



Progettare con la natura

Designing with nature

Adok progetta e produce facendo riferimento alle espressioni della natura e traendo ispirazione dai suoi materiali primari e dalla rinnovabilità.

Adok designs and manufactures by referencing the expressions of nature and drawing inspiration from its primary materials and renewability.

Tutti gli arredi Adok sono realizzati impiegando pannelli in **legno** truciolare melaminico nobilitato, i cui costituenti legnosi derivano da foreste gestite in maniera responsabile e da legno riciclato. Una scelta responsabile che contribuisce non solo alla tutela dell'ambiente, ma anche al conseguimento di benefici sociali e di sostenibilità economica.

Una tutela rivolta parimenti ai consumatori: infatti, il materiale legnoso truciolare, impiegato da Doimo Cityline, risulta certificato dai produttori per la bassissima emissione di formaldeide (un composto organico volatile dannoso per la salute umana) in accordo sia alle disposizioni di legge italiane e comunitarie, che ai regolamenti statunitensi CARB ATCM Phase II /U.S. EPA TSCA Title VI.

Giunti a fine vita gli arredi Adok possono essere avviati totalmente al riciclo dei materiali costituenti. In primis le parti legnose possono essere recuperate per essere trasformate in nuova materia prima destinata a realizzare prodotti sostenibili e funzionali.

All Adok furnishings are made using melamine faced chipboard panels, whose **wood** constituents derive from responsibly managed forests and recycled wood.

A responsible choice that contributes not only to environmental protection, but also to the achievement of social benefits and economic sustainability.

A protection equally aimed at consumers: in fact, the chipboard wood material used by Doimo Cityline is certified by the producers for the very low emission of formaldehyde (a volatile organic compound harmful to human health) in accordance with both the Italian and EU legal provisions, which to the US regulations CARB ATMM Phase II /U.S. EPA TSCA Title VI. Once they have reached the end of their life, Adok furnishings can be totally recycled of the constituent materials.

First of all, the woody parts can be recovered to be transformed into new raw material destined to create sustainable and functional products.

Attraverso opportuni trattamenti, gli **scarti di produzione** derivanti dalla lavorazione del legno e dei relativi semilavorati sono oggi interamente reimmessi nel sistema: in parte destinati alla produzione di nuova materia prima, in parte come fonte per produrre energia termica.

Through appropriate treatments, the **production waste** deriving from the processing of wood and the related semi-finished products are today entirely reintroduced into the system: partly destined for the production of new raw material, partly as a source for producing thermal energy.

Oltre al legno, le parti accessorie, come maniglie e i piedini, dei mobili Adok sono anche realizzate in **alluminio** o **zama**, materiali anch'essi derivanti da processi di riciclo. Grazie alle loro proprietà, anche le leghe di alluminio e zama concorrono a conferire l'elevata circolarità dei prodotti Adok, infatti se conferite correttamente, possono essere riciclate infinite volte senza perdere nessuna delle sue proprietà fisiche e meccaniche. L'impiego di questi materiali metallici (o del legno) ha consentito anche ad Adok di ridurre sensibilmente l'utilizzo di quelli plastici. Ove non è stato possibile operare la sostituzione, per esempio per realizzare certe tipologie di bordi, viene oggi impiegato materiale plastico di elevata qualità (ABS atossico) e completamente riciclabile a fine vita.

In addition to wood, the accessory parts, such as handles and feet, of Adok furniture are also made of **aluminum** or **zamak**, materials also deriving from recycled processes. Thanks to their properties, aluminum and zamak alloys also contribute to giving the high circularity of Adok products, in fact if handled correctly, they can be recycled countless times without losing any of their physical and mechanical properties. The use of these metal materials (or wood) has also allowed Adok to significantly reduce the use of plastic ones. Where it has not been possible to operate the replacement, for example to create certain types of edges, high quality plastic material (non-toxic ABS) and completely recyclable at the end of its life is now used.

Il **vetro** è adottato in maniera consapevole nei processi produttivi Adok, sfruttandone tutte le caratteristiche sostenibili ed estetiche. Materiale sinonimo di trasparenza e leggerezza, può essere riciclato e riciclabile al 100% e quindi reintrodotta infinite volte nel ciclo produttivo.

Glass is consciously adopted in the Adok production processes, exploiting all its sustainable and aesthetic characteristics. Material synonymous with transparency and lightness, it can be 100% recycled and recyclable and therefore reintroduced countless times into the production cycle.

La totale sostituzione delle **vernici** a solvente organico con quelle a base acqua, certificate dai produttori in Classe A+ (indica il più basso livello previsto di emissioni indoor di sostanze dannose, per la salute umana e l'ambiente), nella realizzazione di Adok garantisce elevati standard di salubrità dell'aria e basso impatto ambientale.

The total replacement of organic solvent **paints** with water-based ones, certified by the manufacturers in Class A+ (indicates the lowest expected level of indoor emissions of substances harmful to human health and the environment), in the creation of Adok guarantees high air health standards and low environmental impact.

Tutti gli **apparecchi elettrici ed elettronici** adottati negli arredi Adok, come per esempio lampade e alimentatori, sono certificati RoHS: direttiva europea che impone forti restrizioni alla presenza di sostanze pericolose per l'ambiente e la salute umana e che definisce i stringenti criteri per il recupero e lo smaltimento a fine vita dei dispositivi elettrici ed elettronici.

All **electrical and electronic appliances** used in Adok furnishings, such as lamps and ballasts, are RoHS certified: a European directive which imposes strong restrictions on the presence of substances dangerous for the environment and human health and which defines stringent recovery criteria and end-of-life disposal of electrical and electronic devices.

Anche l'accurata progettazione degli **imballi** di Adok permette di ridurre il quantitativo di rifiuti prodotti e di energia impiegata, e implementa il riciclo e la differenziazione dei materiali.

Even the careful design of Adok's **packaging** makes it possible to reduce the amount of waste produced and energy used, by implementing the recycling and differentiation of materials.

Carta e digitale, ovvero "materia e bit", costituiscono strumenti alternativi che occorre calibrare per una corretta gestione sostenibile delle risorse. Tra le prime aziende del settore arredo Doimo Cityline ha introdotto la **digitalizzazione** di tutti i documenti di vendita e di trasporto destinati ai clienti, di cui Adok ne è parte integrante e rappresentativa di questo processo virtuoso di dematerializzazione. Altresì l'azienda ha adottato una politica di gestione paperless dei documenti e dei processi che contribuisce in maniera rilevante a preservare, eliminando l'impiego massivo di carta, il patrimonio boschivo e a ridurre le emissioni di gas climalteranti.

Paper and digital, or "matter and bits", are alternative tools that need to be calibrated for correct sustainable management of resources. Among the first companies in the furniture sector, Doimo Cityline has introduced the **digitization** of all sales and transport documents intended for customers, of which Adok is an integral and representative part of this virtuous process of dematerialization. The company has also adopted a policy of paperless management of documents and processes which contributes significantly to preserving, by eliminating the massive use of paper, the forest heritage and to reducing climate-altering gas emissions.

L'attività produttiva di Adok si svolge con un'attenta gestione dei **consumi energetici**. Periodicamente il sistema di produzione è sottoposto a diagnosi energetiche finalizzate a migliorarne ulteriormente l'efficienza e le prestazioni. Una particolare attenzione è riservata all'ottimizzazione nell'impiego di energia elettrica per le utilities ad asservimento dei processi produttivi e alla

pianificazione di interventi sull'impianto di illuminazione, con l'introduzione di fonti LED a basso consumo e di sistemi di accensione con rilevatori di presenza.

Adok's production activity takes place with careful management of **energy consumption**. Periodically, the production system is subjected to energy audits aimed at further improving its efficiency and performance. Particular attention is paid to optimizing the use of electricity for utilities serving production processes and planning interventions on the lighting system, with the introduction of low-consumption LED sources and ignition systems with detectors of presence.

I **processi produttivi** Adok sono basati su piattaforme digitali e impianti automatizzati di ultima generazione per il controllo della qualità e la gestione delle risorse. Appositi sistemi software sono dedicati a ottimizzare i piani di taglio e la precisione delle lavorazioni, coniugando l'affidabilità e la facilità di precisi montaggi dei mobili con il massimo contenimento degli scarti di lavorazione. Il controllo attento del prodotto, della snellezza dei processi produttivi e dell'ottimizzazione dei parametri permettono al sistema di garantirne qualità, affidabilità e sicurezza.

Adok **production processes** are based on digital platforms and latest generation automated systems for quality control and resource management. Specific software systems are dedicated to optimizing the cutting planes and machining precision, combining the reliability and ease of precise furniture assembly with maximum containment of manufacturing waste. The careful control of the product, the streamlining of the production processes and the optimization of the parameters allow the system to guarantee its quality, reliability and safety.

Adok nasce ed è espressione di una sostenibilità improntata anche al rispetto dei **diritti dei lavoratori** e allo sviluppo di misure di welfare sociale che ne migliorino il benessere e l'equilibrio tra crescita professionale e vita privata. Le politiche aziendali che adotta Doimo Cityline sono

promotrici di uguaglianza, tutela delle vulnerabilità, inclusione sociale, salute e sicurezza. L'adozione dei Sistemi di Gestione per la Qualità, l'Ambiente e la Sicurezza (declinati nelle certificazioni UNI EN ISO 9001, UNI EN ISO 14001 e UNI ISO 45001) e unitamente al modello organizzativo MOG 231 (D.Lgs. 231 volto a disciplinare le responsabilità amministrative delle Società), che stabilisce un codice etico, permettono all'azienda di gestire i propri processi tramite un sistema di Governance Integrata ed eticamente sostenibile, indirizzato alla creazione di valore e alla garanzia della sostenibilità del business in una prospettiva di lungo periodo.

Adok was born and is the expression of a sustainability also based on respect for **workers' rights** and the development of social welfare measures that improve their well-being and the balance between professional growth and private life. The company policies adopted by Doimo Cityline are promoters of equality, protection of vulnerabilities, social inclusion, health and safety. The adoption of the Quality, Environment and Safety Management Systems (declined in the UNI EN ISO 9001, UNI EN ISO 14001 and UNI ISO 45001 certifications) and together with the MOG 231 organizational model (Legislative Decree 231 aimed at regulate the administrative responsibilities of the Companies), which establishes a code of ethics, allow the company to manage its processes through an Integrated and ethically sustainable Governance system, aimed at creating value and guaranteeing the sustainability of the business in a long-term perspective period.



AD
sciutoarchitetti

Graphic Design
romanoassociati.com

Digital Images
Gabriotti Fotografi

styling
Gabriotti Fotografi

press / pre-press
Grafiche Antiga

printed in Italy
febbraio 2024



I colori riprodotti sono indicativi
e possono differire leggermente
da quelli reali.

The colours reproduced are
indicative and may slightly differ
from the original ones.

ADOK è un marchio
Doimo Cityline Srl
Viale Europa Unita, 12
31010 Moriago della Battaglia TV
Tel. +39 0438 8918
info@adok.it



www.adok.it

Beds & Night Accessories

ADÖK