

Intermezzo Home Freespace

ADÖK

ADOK arreda la tua casa

Intermezzo Home Freespace

ARREDARE
FURNISH
CONTENERE
STORE
SEPARARE
SEPARATE
ORGANIZZARE
ORGANISE
NASCONDERE
CONCEAL

Intermezzo

Lo spazio dove non c'era

Intermezzo, un programma d'armadi concepito con un preciso obiettivo progettuale: aumentare le potenzialità di servizio delle armadiature grazie all'utilizzo rigoroso dello spazio.

Lo spazio dove non c'era significa proprio questo: ogni millimetro di ogni casa viene utilizzato al meglio, sulla base delle esigenze individuali.

Intermezzo realizza un sogno: adeguare il progetto del proprio armadio alle specifiche strutture architettoniche della propria casa, in modo da avere un prodotto su misura come quello fatto da un artigiano, ma con caratteristiche di precisione e perfezione come quelli di un'industria, a costi decisamente economici.

L'armadio al millimetro

La modularità del sistema armadi Intermezzo consente infinite soluzioni tipologiche: grazie alla varietà dei moduli, le dimensioni sono adattabili ad ogni tipo di spazio.

Space where there was none

Intermezzo is a wardrobe/cupboard programme with a precise aim: to increase the service potential of wardrobes and cupboards by exploiting every centimetre of space.

That's the meaning of space where there was none: the utmost use is made of every millimetre of every home to satisfy individual needs.

Intermezzo makes a dream come true: to adapt wardrobe and cupboard design to the specific architectural structure of your home with a customised product that's like one tailor made by an artisan, but with the precision and perfection of an industrialised item costing much less.

Wardrobes/cupboards to the millimetre

Intermezzo is a modular system of wardrobes/cupboards that provides infinite solutions: thanks to the variety of modules, dimensions are adaptable to any kind of space.

02

Cabine armadio a cremagliera
Rack walk-in closet

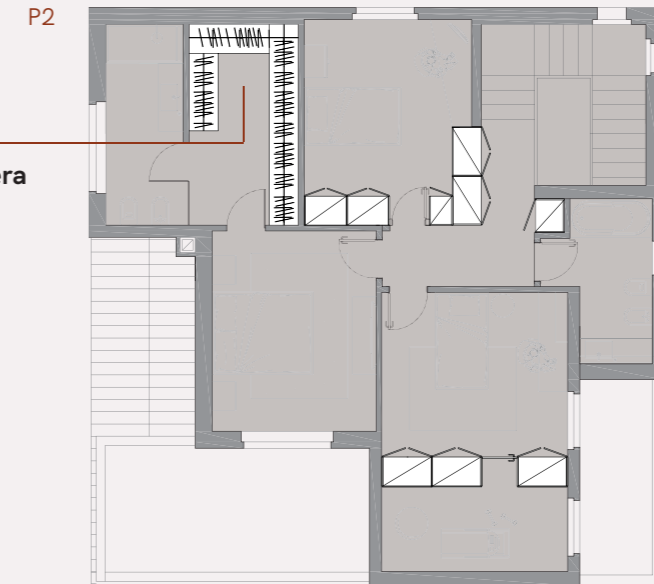

01

Sistema armadio
Wardrobe/cupboard system

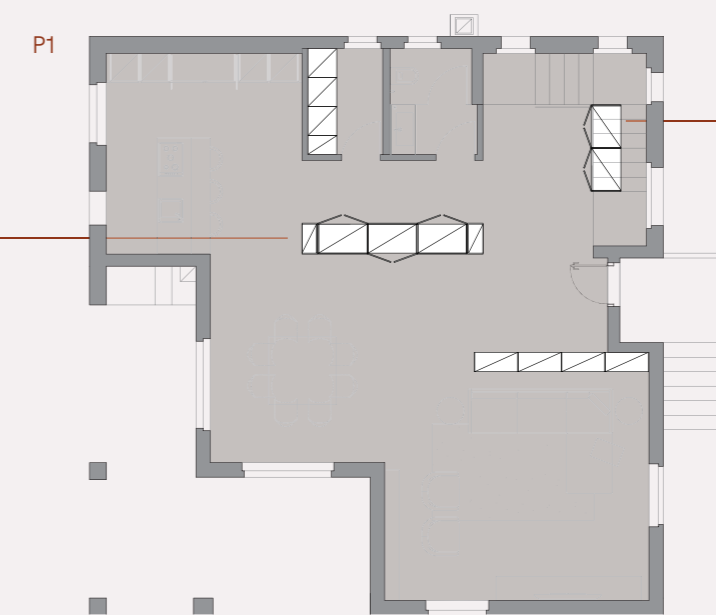

03

Soluzioni speciali
Special solutions

PT

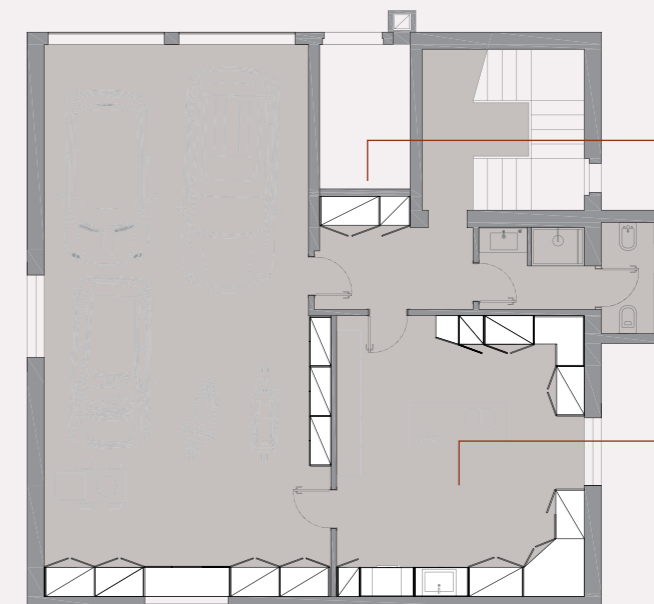

05

Ingresso
Entrances

04

Spazi di servizio
Service space

Indice_Index

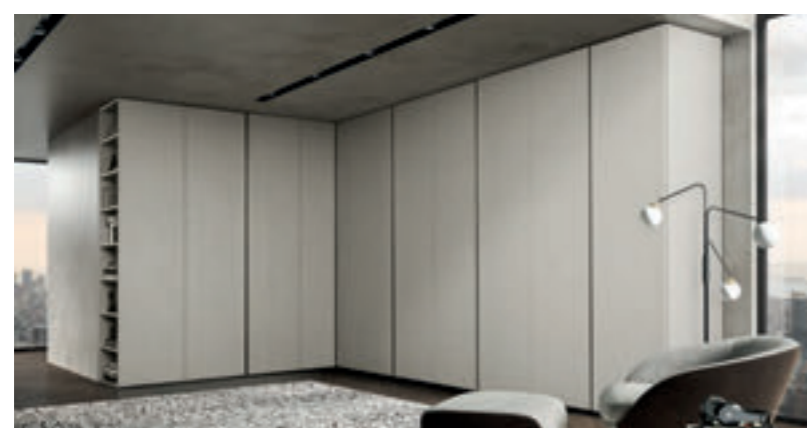

01 > PAG 6

Armadi
Wardrobes



02 > PAG 30

Cabine armadio
Walk-in closets



03 > PAG 50

Soluzioni speciali
Special solutions



04 > PAG 68

Spazi di servizio
Service space



05 > PAG 128

Ingresso
Entrances

Programma armadi Wardrobes/cupboards

Il programma armadi Intermezzo

È dedicato a chi ama il design funzionale: moderno, versatile, rigoroso ed efficiente, consente una grande libertà di scelta ed è capace di rispettare la nostra personalità, garantendo sempre alti livelli di funzionalità. Una collezione caratterizzata dalla molteplicità delle soluzioni possibili e che offre moltissime varianti sia sul piano stilistico, sia sul piano delle attrezzature interne ed esterne.

È una scelta progettuale che garantisce ampi margini di personalizzazione: in questo modo, la soluzione adottata può veramente rispecchiare il nostro modo di concepire l'arredamento.

Intermezzo wardrobes/cupboards is dedicated to those who appreciate functional design: modern, versatile, rigorous and efficient, it provides freedom of choice and will reflect your personality while ensuring great functionality.

Intermezzo is a collection of wardrobes/cupboards featuring a host of solutions that offer many variants in terms of style and internal and external fittings. It is a design choice that ensures great customisation options. In this way the solution adopted will truly reflect your idea of home décor.

Armadio anta battente

Hinged door wardrobe
pag 8

Armadio con anta scorrevole

Sliding door wardrobe
pag 22





Armadio anta battente

Gli armadi delle nostre case: sempre più importanti perché sempre più ricchi di oggetti. Devono contenere il nostro mondo, i nostri abiti e le cose che usiamo ogni giorno. Devono essere progettati per garantire ordine e razionalità: dobbiamo poterli aprire e subito ritrovare ciò che ci serve, individuandolo tra i tanti vestiti che contengono.

Hinged door wardrobe/cupboard

The wardrobes/cupboards in our homes are ever more important because they hold increasingly more objects. They have to contain our world, our clothes and the things we use every day. They must be designed to guarantee tidiness and rationality: we must be able to open them and find what we want immediately.







Un armadio Intermezzo angolare con interno ed esterno Titanio e anta battente Premium spessore 25. Prevede l'angolo attrezzato con tubi appendi abito, terminale della libreria Frame e maniglie a profilo Ruler.

A Intermezzo corner wardrobe with Titanio interior and exterior and Premium 25mm thick hinged door. The corner is equipped with clothes hanger rods, a Frame bookcase end piece and Ruler grip profile.







PAG 144 Attrezzature interne / Internal fittings
09 > Servetto estraibile / Pull-out garment lift

Sono i particolari a rendere personale un armadio: sono le scelte che noi facciamo per quanto concerne finiture e, specialmente, attrezzature interne ed esterne. In queste immagini, il servetto estraibile: un modo semplice di rendere comode le azioni di ogni giorno.

Details make a wardrobe personal: the choices we make regarding finishes and particularly the internal and external fittings. In these pictures, a pull-out garment lift: a simple way to make everyday actions convenient.





PAG 144 Attrezzature interne / Internal fittings
01 > Ripiano inclinato portascarpe / Inclined shelf for shoes

Un vano con ripiani inclinati portascarpe: il programma d'armadi Intermezzo, un progetto che ha al centro il principio di organizzazione efficiente dello spazio, prevede uno specifico elemento dedicato alle nostre scarpe, un modo razionale di tenerle in ordine e di averle costantemente davanti.

A cupboard with inclined shelves for shoes: the Intermezzo wardrobe/cupboard programme is a project based on the principle of efficient organisation of space; it provides a special unit for shoes, a rational way to keep them tidy and have them always to hand.





Armadio anta scorrevole

L'armadio con anta scorrevole è una tipologia d'arredo caratterizzata da due elementi progettuali: il non ingombro delle aperture e la possibilità di avere una visuale ampia sul contenuto dell'armadio. Intermezzo con tipologia scorrevole amplifica quindi la capacità razionale del sistema armadi, adattandosi anche ad ambienti domestici contenuti.

Sliding door wardrobe/cupboard

Sliding door wardrobes/cupboards are characterised by two design elements: doors that do not take up space and a full view of the contents. Intermezzo sliding door versions extend the rational capacity of the wardrobe/cupboard system, also adaptable to areas where space is at a premium.





Armadio Intermezzo con ante scorrevoli Essential dotate di un meccanismo con chiusura rallentata, maniglioni e profili in alluminio sulle ante color Ghisa. La finitura interna è Titanio, quella esterna è laccata Fango. La cassetiera interna a tre cassetti ha maniglia Row color Ghisa. La libreria Frame a giorno in finitura color Fango.

Intermezzo wardrobe/cupboard with Essential sliding door fitted with a soft-closing mechanism, outsize handles and aluminium profiles on the Ghisa coloured doors. The interior has a Titanio finish, and the exterior is lacquered colour Fango. The internal three-drawer set has an Ghisa-coloured Row handle. The Frame open bookcase is Fango coloured.



PAG 144 Attrezzature interne / Internal fittings
03 > Cassetiera interna / Internal drawer set





Cabine Armadio

Walk-in closets

02 >

Cabine Armadio a cremagliera

La cabina armadio è una tipologia d'arredo sempre più presente nelle nostre case perché si fonda su un principio di spazio aperto e di valorizzazione visiva del nostro guardaroba: razionalità organizzativa e flessibilità compositiva sono gli elementi progettuali che ne hanno decretato il grande successo.

La cabina armadio è un elemento d'arredo che rende immediatamente visibili anche i dettagli del prodotto, i materiali e i particolari progettuali.

Eleganza, precisione e qualità sono i nostri punti di riferimento.

Rack walk-in closet

A walk-in closet is an element that not only shows off our collection of clothes and everything we normally keep in closed containers, it also displays the product's details, its materials and design. Elegance, precision and quality are our reference points.

Walk-in closets are increasingly popular in our homes because they are based on the principle of open space and visible enhancement of our collection of clothes: its success is due to the opportunities it offers for rational organisation and flexibility.

Cabina armadio con sistema a cremagliera

Walk-in closet with rack system
Pag 32

"Inventare" lo spazio

'Inventing' space
Pag 40





Cabina armadio con sistema a cremagliera

Le cabine armadio del sistema Intermezzo sono disponibili in diverse versioni tecniche. In questa composizione viene proposta la cabina armadio caratterizzata dal sistema a cremagliera Ta-Tac (color Ghisa) alla quale si agganciano le attrezzature.

Walk-in closet with rack system

Several technical versions are available for Intermezzo system walk-in closets. This composition features a walk-in closet with an Ta-Tac rack system (Ghisa coloured) to which fittings are attached.







La cabina armadio con sistema a cremagliera Ta-Tac: in questa composizione la pannellatura è realizzata con finitura Frassino Normandie, così come la base. La cassetteria e le mensole sono proposte nella finitura Fango. Da sottolineare l'estrema linearità delle maniglie Row color Ghisa coordinate alla cremagliera.

Walk-in closet with Ta-Tac rack system: in this composition the panelling has a Frassino Normandie finish, extended to the base unit. The drawer set and shelves are in Fango finish. Note the linearity of the Ghisa-coloured Row handle coordinated with the rack.



Le cabine armadio Intermezzo offrono una vasta possibilità di scelta per quanto riguarda le attrezzature: in questo modo, ognuno progetta la sua cabina in funzione delle sue preferenze di stile.

Intermezzo walk-in closets provide a wide choice of fittings: in this way everyone plans the style and functions of their closets as they wish.





“Inventare” lo spazio

Una cabina armadio realizzata con il sistema Intermezzo con porta integrata: una soluzione dotata di forte personalità. Grazie alla flessibilità del programma e ai materiali impiegati, un'unica armadiatura consente di separare e coniugare le funzioni del contenere di una zona giorno con quelle della zona notte.

‘Inventing’ space

Walk-in closet featuring the Intermezzo system with integrated door: a solution that oozes personality. Programme flexibility and the materials used create a single wardrobe/cupboard system where the storage functions are separate and combined to furnish both a living room and a bedroom area.





La cabina armadio, una soluzione che non è solo un sogno per chi possiede una camera di grandi dimensioni, ma una scelta praticabile anche in presenza di spazi contenuti. Ciò che conta è la capacità di realizzarla in funzione delle diverse esigenze individuali.

A walk-in closet is a solution that not only furnishes large bedrooms, but is a practical choice also where space is at a premium. What's important is the possibility to adapt to different, individual needs.







Alcuni dettagli della cabina armadio realizzata con sistema a cremagliera Ta-Tac colore Ghisa pannellatura Titanio, mensole e contenitori in Noce Louisiana, con maniglia Quadra 6 Titanio.

Details of a walk-in closet made up with our Ghisa coloured Ta-Tac rack system, Titanio panelling, and Noce Louisiana shelves and storage units, with Quadra 6 Titanio handle.



Per realizzare una cabina armadio capace di rispecchiare le esigenze individuali, il sistema Intermezzo offre un'ampia gamma di attrezzature interne e accessori.

To provide a walk-in closet that meets individual needs the Intermezzo system provides a wide range of internal fittings and accessories.

Soluzioni Speciali

Special solutions

Soluzioni speciali

Intermezzo è il programma ideale per gli spazi che richiedono una progettazione specifica, realizzata su misura, in funzione delle caratteristiche dello spazio da arredare.

Soluzioni destinate ad ambienti domestici dalle varie caratteristiche architettoniche: mansarde o taverne dalle altezze non regolari, pareti divisorie con porte integrate, sottotetti. È la tecnologia che consente al sistema Intermezzo di adattare le sue armadiature alle richieste del pubblico, grazie a una flessibilità che le rende sempre perfettamente su misura. Dei nostri spazi e dei nostri desideri.

Special solutions

Intermezzo special solutions is the ideal programme for areas that require special planning, with customised items suitable for the architecture of the space to be furnished. Special solutions for homes featuring various architectural characteristics: attics or basements with irregular heights, partition walls with incorporated doors, or lofts. The Intermezzo system uses technology to adapt wardrobes/cupboards to people's requirements, providing flexibility that ensures they are always the perfect size. Tailored to your space and wishes.

A misura di spazio

Tailored to space
Pag 52

Dividere lo spazio in modo razionale

Dividing space rationally
Pag 58



03 >





A misura di spazio

L'armadio Intermezzo della mansarda viene qui proposto con anta battente Premium spessore 25 mm con interno Titanio ed esterno Fango. Maniglia Trapezio 100 in metallo color Ghisa. La composizione prevede nella parte centrale un'anta scorrevole in metallo color Ghisa in vetro acidato.

Tailored to space

The Intermezzo attic wardrobe is shown here with a premium 25mm thick hinged door, Titanio inside and fango outside. Trapezio 100 handle in Ghisa coloured metal. The central part of the composition is a Ghisa coloured metal sliding door in acid-etched glass.









Dividere lo spazio in modo razionale

Un sistema armadio realizzato con porta integrata: una soluzione razionale perché utilizza in modo ottimale lo spazio a disposizione, facendo svolgere all'armadio anche la funzione architettonica di elemento divisorio.

Dividing space rationally

A wardrobe/cupboard system with integrated door: a rational solution because it makes the most of the space available, and uses the cupboard as a partition element.





Il dettaglio della maniglia Return in metallo color Ghisa, una precisa scelta estetica che, non interrompendo la superficie dell'armadio, gli conferisce un'estrema linearità.

Detail of the Return handle in Ghisa coloured metal, an aesthetic choice that gives an uninterrupted surface, creating an attractively linear cupboard.





L'armadio Intermezzo viene qui proposto con anta battente Premium spessore 25 mm e maniglia Return in metallo color Ghisa interno in Titanio ed esterno in Noce Louisiana. Il contenitore Club a muro è in Noce Louisiana e ha maniglie Take Tortora. Completano la composizione la libreria Kant colore Ametista, la sedia Hand con base a x e lo scrittoio sagomato color Tortora con gamba Seven bianca.

The Intermezzo cupboard shown here has a Premium 25mm thick hinged door and Return handle in Ghisa coloured metal, with Titanio interior and Noce Louisiana exterior. The Club wall-fitted storage unit is in Noce Louisiana, with Take Tortora handle. The composition is completed by the Kant Ametista coloured bookcase, a Hand chair with X-type base and a Tortora coloured shaped desk with white Seven leg.



Spazi di servizio

Service space

Spazi di servizio

Come può un sistema di armadi trasformarsi in una funzionale lavanderia o in una pratica stireria? O ancora, come può diventare una struttura di servizio per la zona garage? Gli armadi del sistema Intermezzo hanno qualcosa di magico: per risolvere al meglio i nostri problemi, riescono a trasformarsi in modo intelligente.

Service space

How can a wardrobe/cupboard system become a functional laundry room or a practical ironing room? How can it become a service structure for the garage? Cupboards in the Intermezzo system can work magic: they transform themselves into intelligent solutions to our problems.



Lavanderia

Laundry room
Pag 70

Lavanderia/stireria

Laundry/ironing room
Pag 84

Mini garage

Mini garage
Pag 110

Angolo di servizio

Service corner
Pag 122

04 >





La lavanderia, uno spazio ben organizzato

Armadiatura a giorno Intermezzo Titanio con vano per lavatrice e asciugatrice e armadio con anta battente con interno Titanio, esterno Alaska e Maniglia Snap 100 Alaska. L'elemento terminale libreria apribile ha un vano interno da 30 cm. La soluzione prevede la porta scorrevole Dea in finitura Ghisa con vetro acidato.

A laundry, well-organised space

Intermezzo Titanio coloured open cupboard with washing machine and dryer compartment and cupboard with hinged door. Interior Titanio, exterior Alaska and Snap 100 Alaska handle. The end bookshelf element has a 30 cm closed internal compartment. This solution has a Ghisa coloured metal Dea sliding door with acid-etched glass.





In queste immagini viene evidenziata la praticità dei cesti e dei vassoi estraibili in lamiera microforata color Ghisa, in cui riporre abiti e biancheria.

These images underline the practicality of baskets and pull-out trays in Ghisa-coloured micro perforated sheet metal to hold clothes and the washing.

PAG 144 Attrezzature interne / Internal fittings
06 > Cesto estraibile metallo / Pull-out metal basket





PAG 144 Attrezzature interne / Internal fittings
08 > Cesto estraibile in tessuto / Pull-out fabric bag



PAG 144 Attrezzature interne / Internal fittings
06 > Cesto estraibile in metallo / Pull-out metal basket



PAG 144 Attrezzature interne / Internal fittings
05 > Vassoio portacinture-portacravette / Belt-tie tray

Il programma prevede una serie di attrezzature specifiche progettate per la lavanderia: cesto piccolo e cesto grande estraibili in lamiera microforata color Ghisa, la sacca porta biancheria grande e media estraibili in tessuto trapuntato grigio, il vassoio portaoggetti/svuotatasche estraibile.

The programme comes with a series of special fittings designed for laundries: small and large pull-out baskets in Ghisa-coloured micro perforated sheet metal, large and medium sized grey quilted fabric sacks, and a pull-out tidy for emptying pockets.

Un sistema di armadiatura che svolge un'importante funzione di servizio: ai vani destinati a contenere lavatrice e asciugatrice si possono affiancare ripiani o contenitori per tutto ciò che può essere necessario per lavare e stirare.

A cupboard system that has an important service function: the units for washing machines and dryers can be flanked by shelves or storage units for everything necessary for washing and ironing.



Lavanderia: spazio pratico ed efficiente
 Una pratica e funzionale zona lavanderia realizzata con il programma Intermezzo grazie all'utilizzo del sistema a cremagliera Ta-Tac in Ghisa. Ripiani e contenitori sono proposti in finitura bianca.

Laundry: practical, efficient space
 A practical, functional laundry area created with the Intermezzo programme thanks to the use of Ghisa-coloured Ta-Tac rack system. Shelves and storage units come in white.





L'immagine qui sotto pone in evidenza nel dettaglio le caratteristiche della maniglia Snap colore Ghisa. A destra, viene evidenziato lo spessore delle ante e dei ripiani bianchi: sul piano progettuale, il sistema d'armadi Intermezzo garantisce qualità e affidabilità proprio mediante la cura di tutti i particolari.

The image below underlines the details of the Snap, Ghisa-coloured handle. On the right, door and white shelf thickness: the Intermezzo cupboard system guarantees quality and reliability through careful attention to details.





Lavanderia/stireria
Spazio alla funzionalità

Una soluzione per la lavanderia con elementi di servizio utili ed efficaci. L'armadio Intermezzo h 257,5 cm ha tre vani da 60 cm di larghezza, uno dei quali dotato di ionizzatore antibatterico; l'armadio Intermezzo h 132 cm ha due vani da 60 cm di larghezza. Questa composizione utilizza il sistema a cremagliera Ta-Tac in alluminio e può essere attrezzata a piacere.

Laundry/ironing room
Make way for functionality

A laundry room solution with useful, effective service elements: the Intermezzo h 257.5cm cupboard has 3 x 60 cm wide compartments, one of which provided with an anti-bacterial ioniser; the Intermezzo h 132 cupboard has 2 x 60 cm wide compartments. This composition uses the aluminium Ta-Tac rack system and can be equipped to requirements.







L'armadio Intermezzo, con interno Titanio, ante Essential Tortora di spessore 18 mm e frontali della cassetteria esterna Frassino Normandie, è attrezzato con asse da stiro estraibile. Per tutti i contenitori della composizione è prevista la maniglia Ponte 160 finitura Ghisa.

Intermezzo cupboard with Titanio interior, 18mm thick Essential Tortora coloured door and Frassino Normandie coloured external drawer fronts, is equipped with a pull-out ironing board, and large pull-out clothes bag. All storage units in the composition have a Ponte 160 handle with Ghisa finish.







Lo spazio che hai sempre sognato

Una zona lavanderia Intermezzo che prevede la presenza di un'attrezzatura estremamente diversificata, dedicata a questa specifica funzione. La cabina armadio angolare, predisposta per ospitare la lavatrice e il cestello estraibile porta sapone/detersivi, ha l'interno in Titanio e l'esterno bianco.

The space you've always wanted

A Intermezzo laundry area provides the different appliances dedicated to its function. A corner walk-in closet, prepared to accommodate a washing machine and a pull-out basket for soap/deteratives has a Titanio interior and white exterior.







Armadio Intermezzo altezza 100 cm, con 4 vani da 60 cm e cassetti altezza 24 e cassettoni altezza 32. La pannellatura a muro è realizzata in finitura Frassino Normandie. Le mensole e i contenitori Club bianchi con apertura Push-Pull hanno i frontali dallo spessore di 18 mm. Maniglia Presa colore Ghisa.

Intermezzo 100 cm high cupboard with 4 x 60 cm compartments, 24 high drawers and 32 high deep drawers. Wall panelling has a Frassino Normandie finish. White Club shelves and storage units with Push-Pull opening have 18 mm thick fronts. Ghisa Presa handle.





PAG 144 Attrezzature interne / Internal fittings
04 > Telaio portapantaloni / Trousers rack

Nella dotazione di attrezzature specifiche sono previsti anche lo ionizzatore e la lampada Smart con sensore di presenza.

The specific equipment includes an ioniser and Smart lamp with motion sensor.



Armadio Intermezzo per zona lavanderia attrezzato con ripiani, vassoio portaoggetti/svuotatasche estraibile, cesto grande estraibile in lamiera microforata finitura Ghisa, portapantaloni estraibile, portascarpe estraibile applicabile sul fianco e due sacche estraibili porta biancherie per vano da 60.

Intermezzo cupboard for laundry rooms, equipped with shelves, pull-out pocket tidy tray, large Ghisa-coloured pull-out basket in micro perforated sheet metal, pull-out trousers rack, pull-out shoe unit applicable to side and two pull-out clothes sacks for a 60 compartment.







PAG 144 Attrezzature interne / Internal fittings
02 > Portascarpe estraibile / Trouser rack



PAG 144 Attrezzature interne / Internal fittings
10 > Sanificatore / Sanifier

Queste immagini presentano alcuni degli elementi di supporto allo spazio di servizio dedicato alla lavanderia.

These images show some of the elements for service areas dedicated to the laundry.



Mini garage: spazio all'ordine funzionale

Uno spazio tipicamente di servizio come quello destinato ad un mini garage sotto casa può essere risolto con il programma Intermezzo: con questa soluzione, invece di avere attrezzi e utensili riposti in qualche modo, si riesce ad avere uno spazio estremamente funzionale, ordinato e ben organizzato.

Mini garage: orderly, functional space

A typical service space like a basement garage can be created with the Intermezzo programme: with this solution, instead of tools and utensils lying around, space can be functional, orderly and well-organised.







L'armadio Intermezzo ha l'interno Titanio e l'esterno bianco, l'anta Premium con apertura battente e modulo terminale destro. Sulla sinistra, l'armadio Intermezzo di 100 cm di altezza, con top di finitura spessore 18 mm, interno Titanio ed esterno Frassino Normandie.

The Intermezzo cupboard has Titanio interior and white exterior, an Premium hinged door and right-hand end unit. On the left, 100 cm high Intermezzo cabinets, with an 18 mm thick finishing top, Titanio interior and Frassino Normandie exterior.







Sia l'armadio a tutt'altezza con finitura esterna bianca, sia l'armadio di altezza 100 cm con finitura Frassino Normandie sono dotati di maniglia Inside bianca, caratterizzata da un disegno geometrico ed essenziale.

Both the full height white cupboard and the 100 cm high Frassino Normandie cabinets come with a white Inside handle featuring essential, geometrical design.

Il vano da 120 cm è realizzato con divisorio interno attrezzato con ripiani e cesto grande in lamiera microforata estraibile color Ghisa. L'armadio Intermezzo attrezzato con cassetteria interna a tre cassetti per vano da 60 cm con maniglia a profilo Row color Ghisa. Una soluzione di grande praticità che risolve in modo semplice il problema di dove sistemare oggetti per cui è sempre difficile trovare un posto.

The 120 cm compartment has an internal partition equipped with shelves and a large pull-out basket in Ghisa-coloured micro perforated sheet metal. Intermezzo cupboard equipped with internal three-drawer set for a 60 cm compartment, with Ghisa-coloured Row grip profile. A truly practical solution to the problem of finding a place for everything.





Angolo di servizio: minimo ingombro, massimo spazio

In questa composizione, l'armadio Intermezzo speciale ha il vano più profondo per contenimento lavatrice e asciugatrice; la finitura interna è in Titanio, quella esterna in Tortora e Noce Louisiana. Il vano da 30 al millimetro è destinato al contenimento dell'asse da stiro, la maniglia è Snap 100 color Tortora.

Service corner: minimum occupation, maximum space

In this composition, the special Intermezzo cupboard has a deeper compartment to hold a washing machine and dryer; the interior is in Titanio and the exterior in Tortora and Noce Louisiana. The 30mm compartment with a Tortora-coloured Snap 100 handle is designed to accommodate an ironing board.





Una soluzione che dimostra come si può sfruttare bene lo spazio a disposizione: il sistema di armadi Intermezzo consente di risolvere in modo ottimale la zona lavanderia, anche con limitate superfici disponibili.

A solution that demonstrates how to make the most of the space available: the Intermezzo cupboard system can create a fantastic laundry area even with limited space.



Ingresso

Entrances

Ingresso

Entrare in una casa e percepire immediatamente una sensazione di ordine. Il programma armadi Intermezzo, con le sue dotazioni dedicate alle zone della casa, permette di organizzare al meglio le funzioni di servizio delle diverse aree domestiche. In queste pagine vengono presentate le soluzioni per un arredo ideale dell'ingresso. Diverse le esigenze, molteplici le soluzioni. Il sistema Intermezzo offre un'ampia gamma di soluzioni per arredare la zona ingresso della casa.

Entrances

When you enter your home it's good to perceive a sense of order immediately. The Intermezzo wardrobe/cupboard system, with its solutions dedicated to different areas of the house, organises the service functions of each area. These pages show the solutions for furnishing the perfect entrance. Entrances with different needs and a host of solutions. The Intermezzo system provides a wide range of solutions for furnishing entrances.

Ingresso: spazio all'ordine

Entrances: make way for order
pag 130

Tutti gli spazi possibili

As much space as possible
pag 136



05 >





Ingresso: spazio all'ordine

Per la zona ingresso, non è importante l'ampiezza dello spazio a disposizione: ciò che conta è saperlo sfruttare in maniera intelligente e razionale. Infatti, la versatilità del sistema Intermezzo consente un alto livello di personalizzazione anche in spazi ridotti.

Entrances: make way for order

The amount of space available is not important for an entrance: what counts is knowing how to make full use of it intelligently and rationally. The versatility of the Intermezzo system gives great customisation, even in limited space.



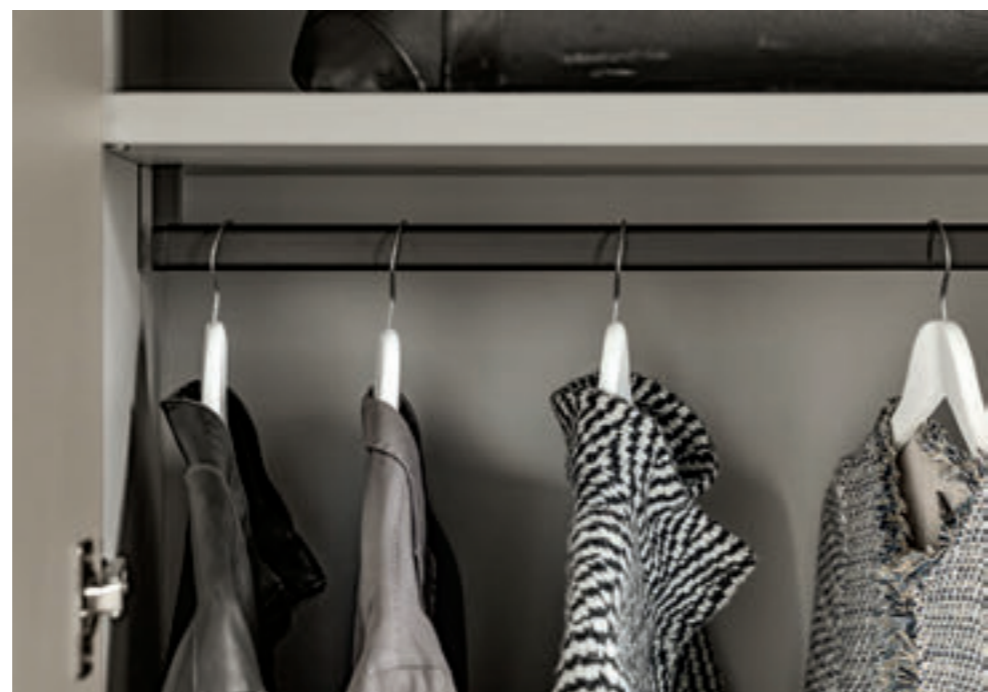

PAG 144 Attrezzature interne / Internal fittings
02 > Portascarpe estraibile / Trouser rack







Tutti gli spazi possibili

Il sistema Intermezzo è ideale per arredare tutte quelle zone della casa che, in passato, prevedevano l'intervento su misura di un artigiano. In questa composizione viene presentata una soluzione che si adatta perfettamente al sottoscala.

As much space as possible

The Intermezzo system is ideal for furnishing those areas of the house that used to require products made to measure by artisans. This composition shows a solution that adapts perfectly to the space under the stairs.







Armadio Intermezzo sottoscala con interno Titanio ed esterno Tortora; l'anta Premium, con apertura Push-pull, ha lo spessore di 25 mm. Nella composizione è previsto un terminale di collegamento con ripiani sagomati a giorno. Nella pagina successiva, mobile Club a parete con apertura Push-pull laccato Baltico.

Intermezzo cupboard to fit under stairs, with Titanio interior and Tortora exterior. Its Premium door is only 25 mm thick and has a Push-pull opening. The composition comprises an end unit with open shaped shelves. On the next page, a Baltico-lacquered Club wall unit with Push-Pull opening.





Informazioni tecniche
Technical information

Attrezzature interne Internal fittings



Il sistema di armadi Intermezzo rappresenta sempre una soluzione di grande validità. È possibile scegliere con assoluta libertà le attrezzature interne di servizio che meglio si adattano alle nostre esigenze, ovviamente cercando di utilizzare al meglio lo spazio. In queste immagini, presentiamo le attrezzature interne del sistema, disponibili in una grande varietà.

The Intermezzo wardrobe/cupboard system is always a valid solution. In this way, you have the freedom to choose the internal fittings best suited to your need to use the space available as rationally as possible. These images present the many internal fittings available.

Attrezzature interne

Internal fittings

01



02



01 Ripiano inclinato portascarpe
02 Portascarpe estraibile
03 Cassetiera interna
04 Telaio portapantaloni
05 Vassoio portacinture/portacravatte
06 Cesto estraibile metallo

01 Inclined shelf for shoes
02 Pull-out shoe rack
03 Internal drawer set
04 Trouser rack
05 Belt/tie tray
06 Pull-out metal basket

03



05

04



06

Attrezzature interne

Internal fittings

07



07 Divisorio interno
08 Cesto estraibile in tessuto
09 Servetto estraibile
10 Sanificatore
11 Cassettiera interna
12 Appendi gruccia estraibile

08



07 Internal partition
08 Pull-out fabric bag
09 Pull-out garment lift
10 Sanifier
11 Internal drawer set
12 Pull-out clothes rod

09



11

10



12

Intermezzo

L'armadio a misura di spazio

La modularità del sistema armadi Intermezzo consente infinite soluzioni tipologiche: grazie alla varietà dei moduli, le dimensioni sono adattabili ad ogni tipo di spazio. Il sistema armadi Intermezzo, prevede le aperture scorrevole e a battente.

La dimensione delle ante può variare a seconda delle scelte del cliente.

Wardrobes/cupboards made to fit the space available

Intermezzo is a modular system of wardrobes/cupboards that provides infinite solutions: thanks to the variety of modules, dimensions are adaptable to any kind of space. The Intermezzo wardrobe/cupboard system comes with sliding and hinged doors. Door size can vary according to customers' choices.

Armadi anta battente

Hinged door modularity



Librerie

Bookcases



Colonne per lavatrice/asciugatrice

Dryer/ washing machine tall units

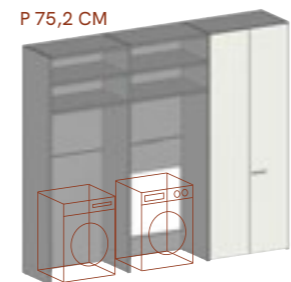

Armadi anta scorrevole

Sliding door modularity

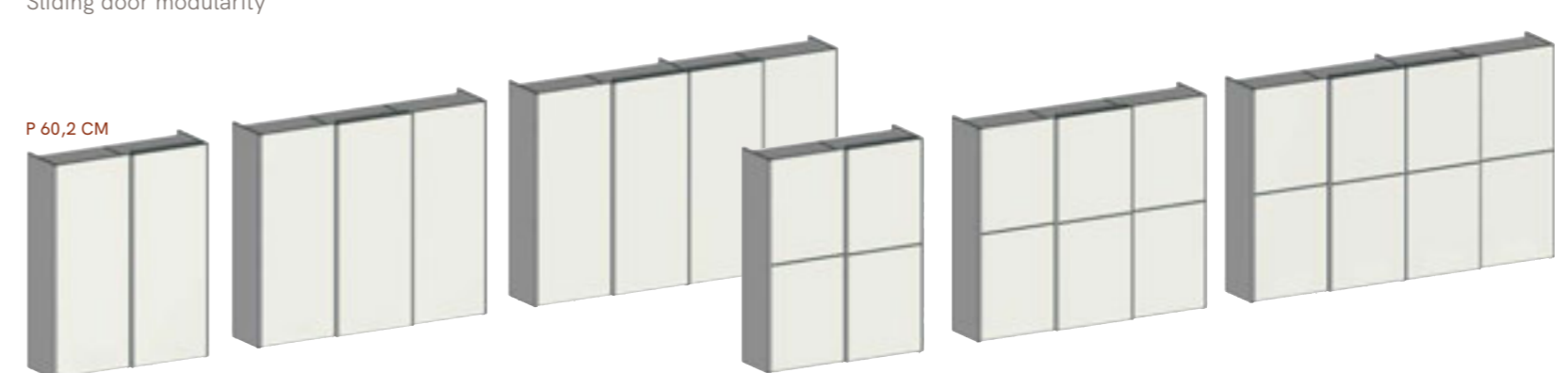

Cremagliere

Racks

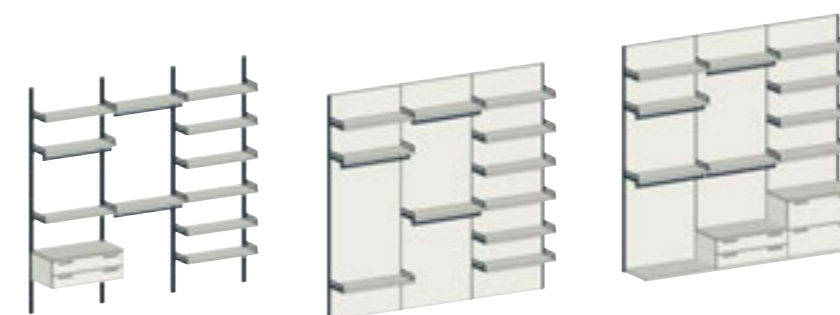

Intermezzo

L'armadio al millimetro

Intermezzo è un programma che consente la più ampia libertà di scelta per quanto riguarda il numero e le dimensioni delle ante: qualsiasi misura di larghezza, come evidenziato nei disegni di lato, può essere ottenuta con un numero differente di ante. Al millimetro e a catalogo.

Intermezzo wardrobes/cupboards to the millimetre

Intermezzo is a programme that provides freedom to choose the number and size of doors. As the drawings on the show, different numbers of doors can be used to achieve any width. To the millimetre and in the catalogue.

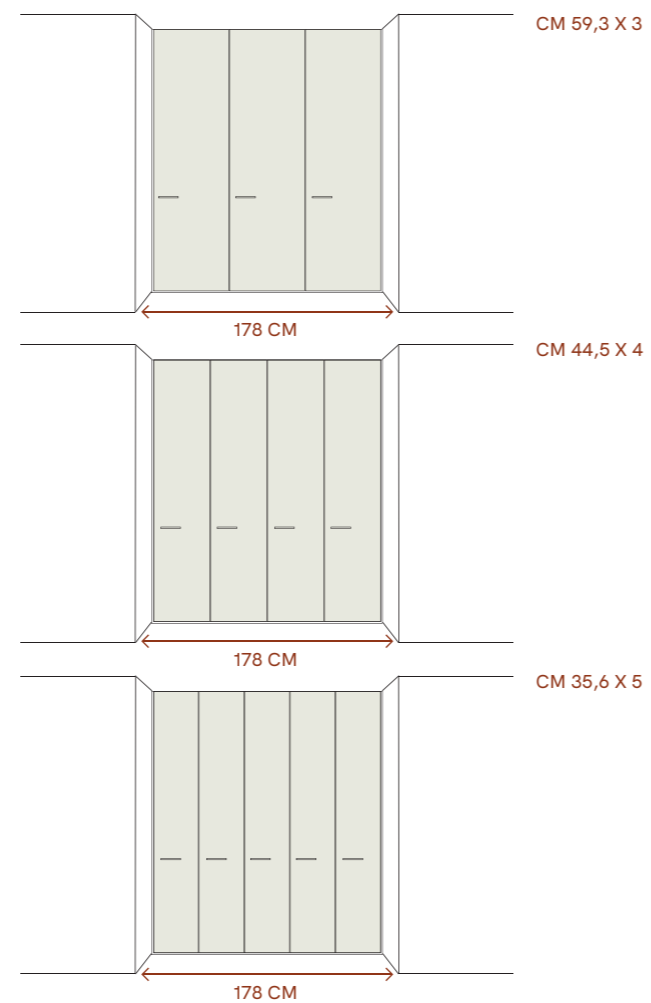

Intermezzo

Un programma versatile

Grazie ai tagli su misura, Intermezzo garantisce la massima versatilità. Ogni proposta tipologica può essere personalizzata in qualsiasi dimensione e con precisione millimetrica, con e senza tamponamenti finali, ma con pannelli ed ante realizzate su misura.

Intermezzo. A versatile programme

Intermezzo provides great versatility by cutting to size. Every type proposed can be customised with any dimensions and millimetric precision. With or without filler panel and with customized doors and panels.

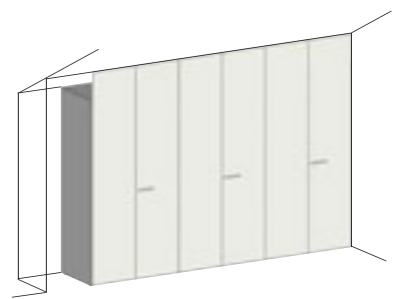
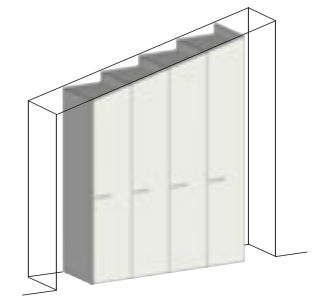

Tagli per mansarda
Sloped cuts

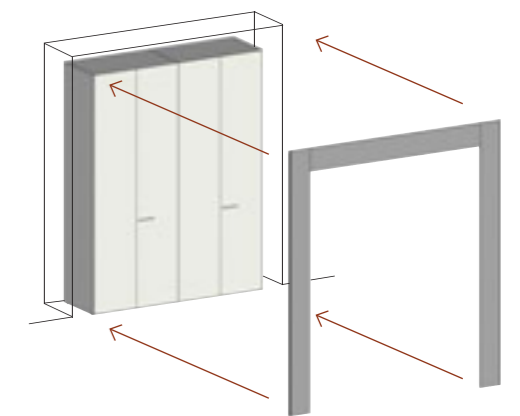

Tamponamenti
Infill

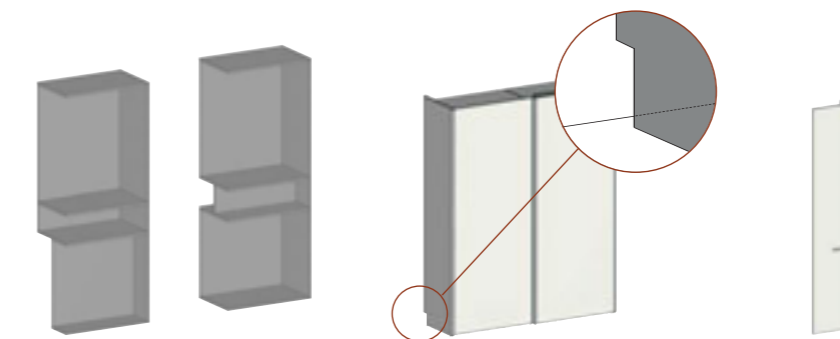

Vano con schienale removibile
Compartment with removable back

Taglio spalla per battiscopa
Cut for baseboard

Anta terminale a misura
Customized end door

Intermezzo Terminali, angolari e cabine

Nel programma Intermezzo sono disponibili elementi terminali ed elementi angolari, a giorno oppure con anta, oltre che gli elementi cabine.

Questi ultimi sfruttano al massimo gli spazi angolari, con la possibilità di installare anche elettrodomestici al loro interno.

Intermezzo end elements, angular elements and cabins

In the programme Intermezzo are available end elements and angular elements, open or with door, in addition to cabin elements.

The latter exploit maximum angular spaces, with the possibility to install also appliances within them.

Elementi terminali End elements

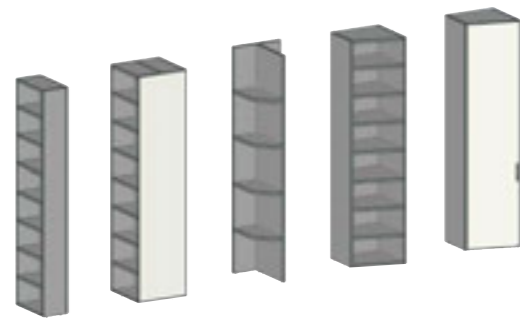

Elementi angolari Angular elements

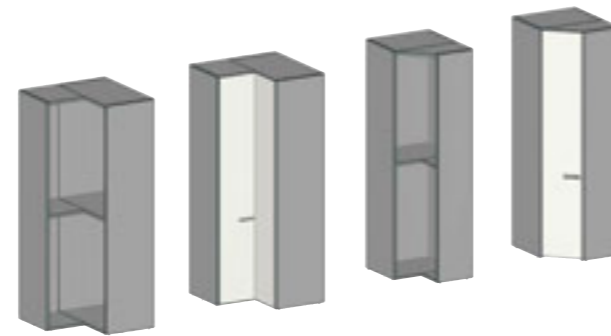

Cabine Cabins

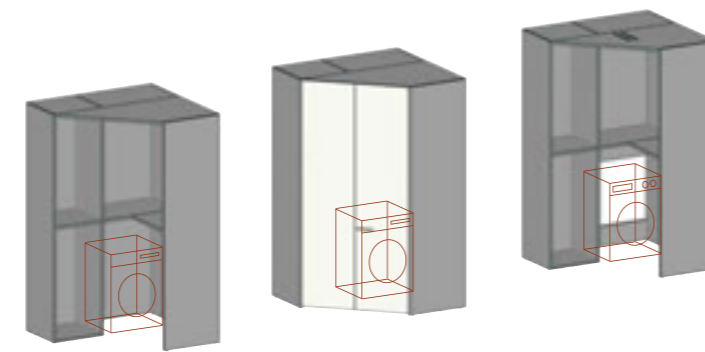
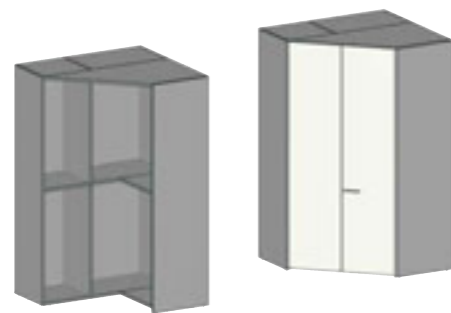

Cabina per asciugatrice
Dryer cabin

Cabina per asciugatrice
Dryer cabin

Cabina per lavatrice
Washing machine cabin

Intermezzo Pensili, ponti e porte

Completano il programma Intermezzo le librerie sospese, gli elementi a ponte, i passaggi porta e le porte scorrevoli; tutti elementi indispensabili per creare un sistema integrato di contenitori che si adatti ai tuoi spazi.

Intermezzo wall units, overhead units and doors

The Intermezzo programme is completed by suspended bookcases, overhead unit elements, door passages and sliding doors.

All of these elements are essential to create an integrated system of containers suitable for your spaces.

Librerie sospese Suspended bookcases



Elementi per ponte Overhead unit elements



Passaggi porta Door passage



Porte scorrevoli Sliding doors



Indice delle composizioni
Composition index

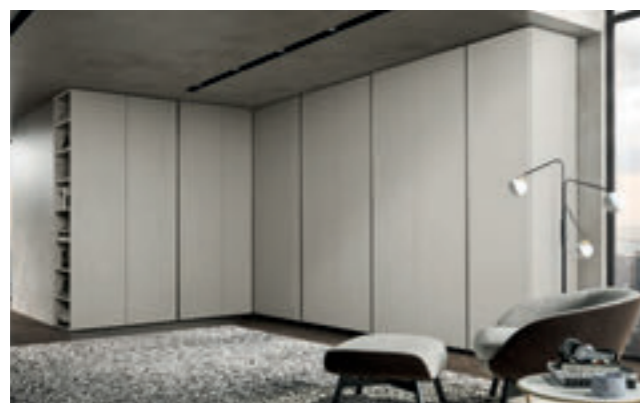

> **PAG 8** Armadio anta battente
Hinged door wardrobe/cupboard



> **PAG 22** Armadio anta scorrevole
Sliding door wardrobe/cupboard



> **PAG 32** Cabina armadio con sistema a cremagliera
Walk-in closet with rack system



> **PAG 40** "Inventare" lo spazio
'Inventing' space



> **PAG 52** A misura di spazio
Tailored to space



> **PAG 58** Dividere lo spazio in modo razionale
Dividing space rationally



> **PAG 70** La lavanderia, uno spazio ben organizzato
A laundry, well-organised space



> **PAG 78** Lavanderia: spazio pratico ed efficiente
Laundry: practical, efficient space



> **PAG 84** Lavanderia/stireria. Spazio alla funzionalità
Laundry/ironing room. Make way for functionality



> **PAG 94** Lo spazio che hai sempre sognato
The space you've always wanted



> **PAG 110** Mini garage: spazio all'ordine funzionale
Mini garage: orderly, functional space



> **PAG 122** Angolo di servizio: minimo ingombro, massimo spazio
Service corner: minimum occupation, maximum space



> **PAG 130** Ingresso: spazio all'ordine
Entrances: make way for order



> **PAG 136** Tutti gli spazi possibili
As much space as possible



Intermezzo utilizza vernici a base d'acqua per le proprie laccature: garantisce così qualità e durata nel tempo ai prodotti, tutela l'ambiente e la salute di chi li utilizza. Le laccature presentano un tatto vellutato (soft touch) sono "anti-impronta", resistenti alla luce, ai graffi e ai segni lucidi grazie all'innovativa tecnologia di "rigenerazione".

I prodotti realizzati con queste vernici:

- Sono privi di metalli pesanti conseguendo l'importante certificazione che attesta il rispetto della normativa EN71 (Parte 3 "sicurezza dei giocattoli, migrazione di determinati elementi") che ne comprova la sicurezza anche nel contatto prolungato con pelle, bocca o lingua.
- Non contengono formaldeide, sostanze biocide o fungicide.
- Grazie alle scarsissime emissioni di COV (Composti Organici Volatili) il prodotto verniciato risulta amico dell'uomo e dell'ambiente.

Intermezzo lacquers are water-based, guaranteeing product quality and durability, environmental friendliness and protection of users' health. Lacquered surfaces are soft touch and fingerprint proof, and an innovative 'regenerating' technology makes them resistant to light, scratches and shiny patches.

The products made with these paints:

- Are free of heavy metals obtaining the important Certification that expected compliance with the EN71 regulation (Part 3 "safety of toys, migration of certain elements") which proves its safety even in prolonged contact with skin, mouth or tongue.
- Do not contain formaldehyde, biocidal substances or fungicides.
- Thanks to the very low emissions of VOC (Volatile Organic Compounds) the painted product is a friend of man and the environment.



Intermezzo garantisce che l'intero ciclo produttivo dei propri prodotti sia totalmente realizzato in Italia.

Intermezzo guarantees that its products are made entirely in Italy.



Per garantire un contenuto di formaldeide addirittura inferiore del 50% rispetto ai limiti imposti dalle normative europee, tutti i mobili intermezzo sono prodotti con pannelli CARB P2.

To guarantee formaldehyde contents even lower 50% than the limit imposed by EU standards, all Intermezzo furniture is produced with CARB P2 panels.



Intermezzo ha ottenuto le certificazioni internazionali UNI EN ISO 9001, UNI EN ISO 14001 e UNI ISO 45001:2018. Tutte le attività aziendali, dalla progettazione agli ordini di acquisto, dalla produzione alla gestione degli ordini clienti, seguono una gestione corretta: in termini di qualità, termini ambientali ed in termini di sicurezza.

Intermezzo has achieved UNI EN ISO 9001, UNI EN ISO 14001 and UNI ISO 45001:2018 international certification. All our company's activities, from design to purchase orders and production to customer order management, follow a proper management: in terms of quality, environment and safety.



Con la certificazione FSC® (Forest Stewardship Council®) Intermezzo garantisce la fabbricazione con utilizzo di pannelli certificati FSC®, cioè prodotti che derivano da foreste gestite in modo responsabile da un punto di vista etico, sociale ed economico.

FSC® (Forest Stewardship Council®) certification allows Intermezzo to fabricate FSC® certified products, that is to say products deriving from forests managed in an environmentally appropriate, socially beneficial and economically viable way.



Il marchio "100% Energia Pulita" Dolomiti Energia rappresenta una nuova concezione di consumo energetico: il marchio promuove l'utilizzo di energia idroelettrica prodotta dalle centrali di proprietà del Gruppo Dolomiti Energia site in Trentino, quindi da fonti totalmente rinnovabili.

The label Dolomiti Energia '100% Clean Energy' is a new energy consumption concept: it promotes the use of totally renewable hydroelectric energy produced by the Trentino-based power stations of Gruppo Dolomiti Energia Group.

AD
sciutoarchitetti

Graphic Design
romanoassociati.com

Digital Images
Linkfoto

styling
Linkfoto

press / pre-press
Grafiche Italprint

printed in Italy
Gennaio 2022

ADOK è un marchio
Doimo Cityline Srl
Viale Europa Unita, 12
31010 Moriago della Battaglia TV
Tel. +39 0438 8918
Fax +39 0438 892922
info@adok.it
www.adok.it

ADOK è un marchio Doimo Cityline Srl

Viale Europa Unita, 12 / 31010 Moriago della Battaglia TV Tel. +39 0438 8918 / Fax +39 0438 892922